

# Spring-operated brake **INTORQ BFK457**

Now also available in a low-noise design < 50 dbA  
0.12 – 125 Nm



**INTORQ**

setting the standard



## Compact and quickly installed INTORQ BFK457

In many applications, all that is required of the brake is that it fulfils its basic function. For such situations the BFK457 is just the job. The fact that it can also be installed quickly using the integral fixing screws and fixed air gap makes this spring-operated brake even more attractive.

Thanks to the quality standards which we apply to research and development, the choice of materials, production and assembly, the new INTORQ BFK457 spring-operated brakes meet the highest demands. These electromagnetically released brakes can be used wherever rapid deceleration or controlled holding of inertial masses are required.

Since the braking force comes from pressure springs, the braking torque, which is generated by friction, is available when no current is applied – even in the event of a mains failure. The brake is released electromagnetically.

### Application areas

- General mechanical engineering
- Electric motors
- Vehicles for the disabled
- Automation technology
- Sports and recreation
- Rotary indexing technology
- Industrial trucks
- Hoists
- Conveyor technology
- Wood processing machines

**Sizes 01/02/03/04/05**

- Braking torques: 0.12–4 Nm (5 sizes)
- Compact design:
  - Fully assembled with rotor and flange
- Can be mounted on both sides
- Manual release available as an option



COMPACT, SIZES 01 AND 02



COMPACT, SIZES 03, 04, 05

**Sizes 06/08/10/12/14/16**

- Braking torques: 4–125 Nm (6 sizes)
- Emergency manual release
- Designs:
  - Compact: Fully assembled with rotor and flange
  - Basic: Stator complete with rotor
- Manual release available as an option



COMPACT

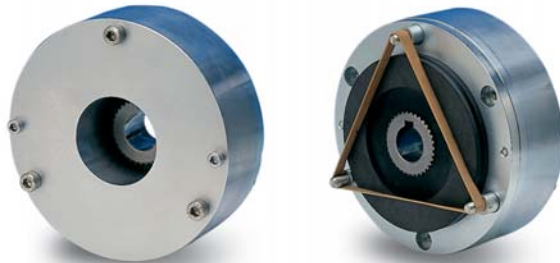

BASIC

**Additional features for all sizes**

- Standard voltages DC 24 V and 205 V (other voltages on request)
- Thermal class F (155 °C)
- Compact design with flange – for small overall dimensions
- Easy assembly by means of the integrated fixing screws
- No fixed bearing required on the brake



MANUAL RELEASE (OPTIONAL)



NOW ALSO AVAILABLE IN A LOW-NOISE DESIGN < 50 dbA (OPTIONAL)

# Spring-operated brake INTORQ BFK457-01 ... 05

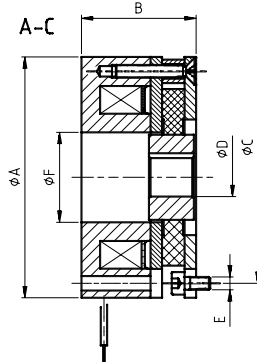
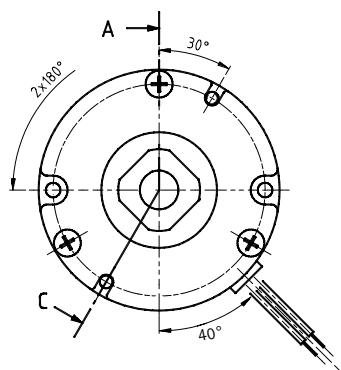

Installation, flange side

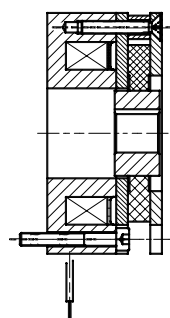

Sizes 01 and 02

Installation, stator housing side

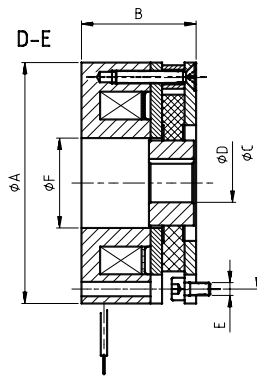
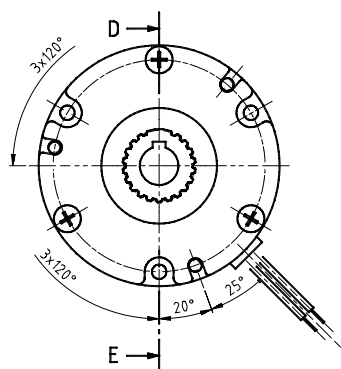

Sizes 03 to 05

Size	$M_K$	$M_{Kmax}$	$P_{20^\circ}$	DH7	$\phi A$	B	$\phi C$	$\phi E$	$\phi F$	H3	$S_{Lü}^2$	$S_{Lü max}$	m
01	0.12	0.24	5	6 <sup>1</sup>	37	31.3	32	2xM2.5	13.5	9	0.15 ±0.1 -0.05	0.35	0.2
02	0.25	0.5	6.6	7 <sup>1</sup>	47	31	40	2xM3	16	12			0.25
03	0.5	1.0	9	6/7/9	56	31.8	48	3xM3	19	15			0.4
04	1	2.0	11.5	7/8/10	65	33.8	58	3xM3	24	15			0.55
05	2	4.0	13	8/10/11/12	75	35.9	66	3xM4	28	15			0.8

<sup>1</sup> Without keyway

<sup>2</sup> Minimum air gap, the actual value is determined by the sum tolerances of the individual components

Size	$M_K$ [Nm]	Max. speed $\Delta n_{o max}$ [rpm]	Max. permissible friction work per operation $Q_E$ [J]	Transition operating frequency $S_{hü}$ [h <sup>-1</sup> ]	Operating times [ms] with standard rated torque and $S_{Lü rated}$ DC switching Release			
					$t_{11}$	$t_{12}$	$t_1$	$t_2$
01	0.12	5000	200	160	2	9	11	17
02	0.25		400	125	3	5	8	17
03	0.5		800	100	5	7.5	12.5	18
04	1		1200	90	9	9	18	23
05	2		1800	80	10	16	26	35

■ Voltages: 24 V, 205 V, (103 V)

■  $M_K$ : Rated torque for the brake in Nm, referred to  $\Delta n = 100$  rpm

**Caution!** The braking torque depends on the speed

■  $P_{20}$ : Coil power at 20 °C in W

■ Standard keyway according to DIN 6885/1-P9

■ Length of the connecting cable: 400 mm

■ All dimensions in mm

■ Subject to modifications.

# Spring-operated brake INTORQ BFK457-06 ... 16

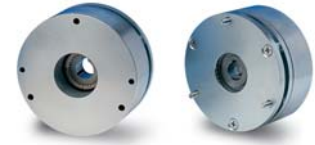

Compact design, fully assembled with rotor and flange

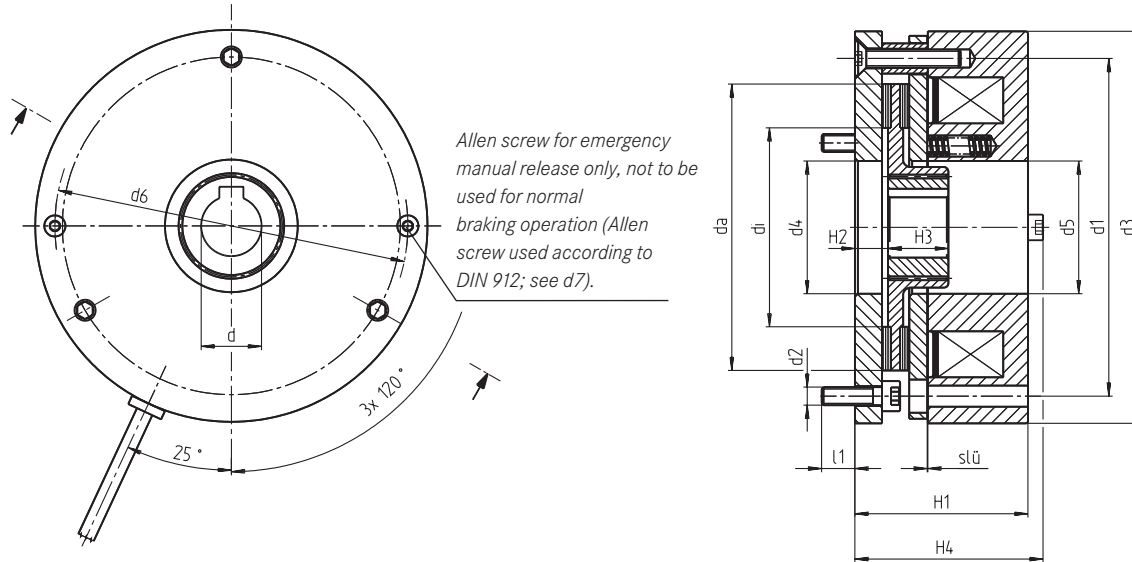

Size	$M_K$	$M_{K \max}$	$P_{20^\circ}$	$d_{I7}$ pilot	$d^{H7}$ standard	d1	d2	d3	d4	d5	d6	d7	da	di	H1	H2	H3	H4	l1*	l2	$S_{l\ddot{u}} \pm 0.1$	$S_{l\ddot{u}}^{\max}$ at $M_K$	$S_{l\ddot{u}}^{\max}$ at $M_{K \max}$	m (kg)
06	4	6	20	10	11/12/14/15	72	3xM4	84	31	31	77	M4x30	60	40	41.3	7.5	18	45.3	6	400	0.2	0.6	0.4	1.1
08	8	12	25	10	11/12/14/15/20	90	3xM5	102	42	41.5	93.5	M5x35	77	47	49.8	8.5	20	54.8	9	400	0.2	0.6	0.45	1.9
10	16	23	32	10	15/20	112	3xM6	130	44	44	117	M5x40	95	66	56.4	10	20	61.4	12	400	0.2	0.7	0.5	3.8
12	32	46	40	14	20/25	132	3xM6	150	52	52	136.3	M5x45	115	70	62.4	10	25	67.4	12	400	0.3	0.8	0.5	5.7
14	60	95	53	14	20/25/30	145	3xM8	165	60	60	150	M6x55	124	80	77.3	13	30	83.3	14	400	0.3	0.8	0.5	8.6
16	80	125	55	15	25/30/35/38	170	3xM8	190	70	70	174.5	M6x60	149	104	83.5	13.3	30	89.5	14	600	0.3	0.9	0.6	12.0

Size	$M_K$ [Nm]	Max. speed $\Delta n_{o \max}$ [rpm]	Max. perm. friction work per operation $Q_E$ [J]	Transition operating frequency $S_{h\ddot{u}}$ [h <sup>-1</sup> ]	Operating times [ms] with standard rated torque and $S_{l\ddot{u}}^{\text{rated}}$ DC switching			
					t <sub>11</sub>	t <sub>12</sub>	t <sub>1</sub>	t <sub>2</sub>
06	4	12400	3000	79	29	19	48	37
08	8	10100	7500	50	60	35	95	42
10	16	8300	12000	40	35	60	95	100
12	32	6700	24000	30	45	53	98	135
14	60	6000	30000	28	50	57	107	240
16	80	5300	36000	27	71	50	121	275

- Standard voltages for:
  - Sizes 06-12: 24 V; 205 V
  - Sizes 14-16: 24 V; 42 V; 205 V
- $M_K$ : Rated torque of the brake in Nm, referred to  $\Delta n = 100$  rpm  
**Caution!** The braking torque depends on the speed, refer to the Operating Instructions.
- $P_{20^\circ}$ : Coil power at 20 °C in W, deviation up to  $\pm 10\%$  is possible depending on the selected supply voltage.

- \* Please contact the manufacturer if a different mounting surface made of steel is used.
- Standard keyway according to DIN 6885/1-P9
- l2: Length of the connecting cable
- All dimensions in mm



# Spring-operated brake INTORQ BFK457-06 ... 16

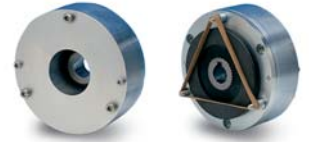

## Basic design: Stator complete with rotor

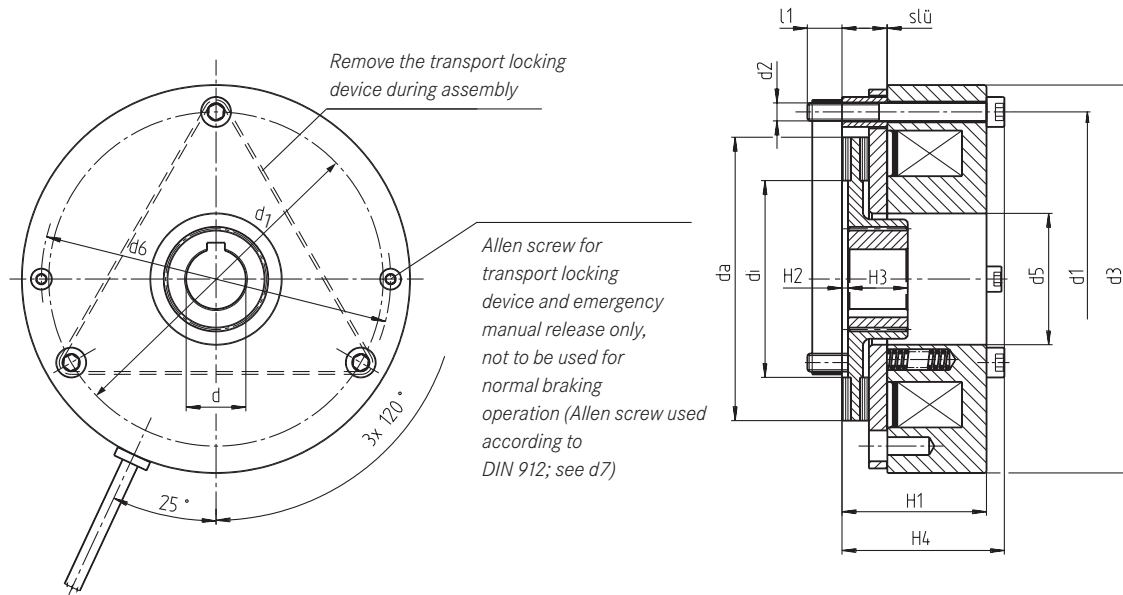

Size	M <sub>K</sub>	M <sub>K</sub> max.	P <sub>20</sub>	d <sub>l7</sub> pilot	d <sup>H7</sup> standard	d1	d2	d3	d5	d6	d7	da	di	H1	H2	H3	H4	l1*	l2	S <sub>ü</sub> ± 0.1	S <sub>ü</sub> max at M <sub>K</sub>	S <sub>ü</sub> max at M <sub>K</sub> max	m (kg)
06	4	6	20	10	11/12/14/15	72	3xM4	84	31	77	M4x30	60	40	35.3	1	18	39.3	9.7	400	0.2	0.6	0.4	0.9
08	8	12	25	10	11/12/14/15/20	90	3xM5	102	41.5	93.5	M5x35	77	47	42.8	1.5	20	47.8	12.2	400	0.2	0.6	0.45	1.5
10	16	23	32	10	15/20	112	3xM6	130	44	117	M5x40	95	66	48.4	2	20	54.4	11.5	400	0.2	0.7	0.5	3.0
12	32	46	40	14	20/25	132	3XM6	150	52	136.3	M5x45	115	70	54.4	2	25	60.4	11	400	0.3	0.8	0.5	4.7
14	60	95	53	14	20/25/30	145	3XM8	165	60	150	M6x55	124	80	66.3	2	30	74.3	14	400	0.3	0.8	0.5	7.1
16	80	125	55	15	25/30/35/38	170	3xM8	190	70	174.5	M6x60	149	104	72.5	2.25	30	80.5	12.5	600	0.3	0.9	0.6	10.0

Size	M <sub>K</sub> [Nm]	Max. speed Δn <sub>o</sub> max [rpm]	Max. perm. friction work per operation Q <sub>E</sub> [J]	Transition operating frequency S <sub>hü</sub> [h <sup>-1</sup> ]	Operating times [ms] with standard standard rated torque and S <sub>Lü</sub> rated Release			
					t <sub>11</sub>	t <sub>12</sub>	t <sub>1</sub>	t <sub>2</sub>
06	4	12400	3000	79	29	19	48	37
08	8	10100	7500	50	60	35	95	42
10	16	8300	12000	40	35	60	95	100
12	32	6700	24000	30	45	53	98	135
14	60	6000	30000	28	50	57	107	240
16	80	5300	36000	27	71	50	121	275

- Standard voltages for:
  - Sizes 06-12: 24 V; 205 V
  - Sizes 14-16: 24 V; 42 V; 205 V
- M<sub>K</sub>: Rated torque of the brake in Nm, referred to Δn = 100 rpm
- **Caution!** The braking torque depends on the speed, refer to the Operating Instructions.
- P<sub>20</sub>: Coil power at 20 °C in W, deviation up to ± 10% is possible depending on the selected supply voltage.
- \* Please contact the manufacturer if a different mounting surface made of steel is used.
- Standard keyway according to DIN 6885/1-P9
- l2: Length of the connecting cable
- All dimensions in mm

# Spring-operated brake INTORQ BFK457-06 ... 16



Basic and compact design with assembled manual release

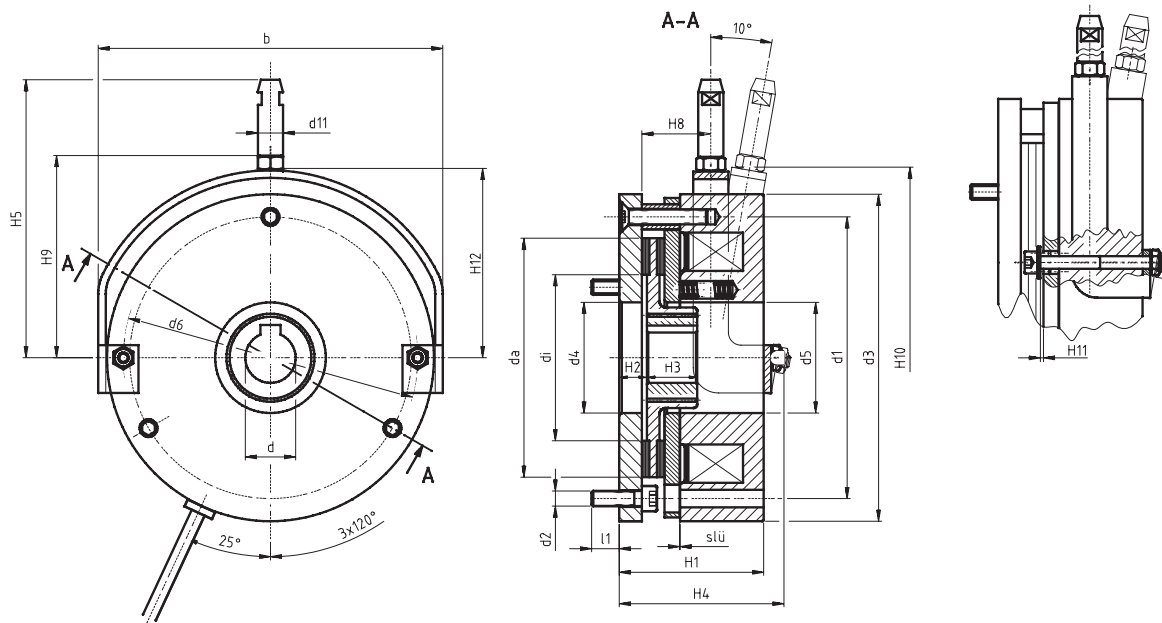

Size	M <sub>K</sub>	M <sub>K max.</sub>	P <sub>20°</sub>	b	d <sub>J7 pilot</sub>	d <sup>H7</sup> standard	d <sup>H7 max.</sup>	d1	d2	d3	d4	d5	d6	d7	d11	da	di	H1	H2
06	4	6	20	90	10	11/12/14/15	15	72	3xM4	84	31	31	77	M4x30	8	60	40	41.3	7.5
08	8	12	25	108	10	11/12/14/15/20	20	90	3xM5	102	42	41.5	93.5	M5x35	8	77	47	49.8	8.5
10	16	23	30	137	10	15/20	20	112	3xM6	130	44	44	117	M5x40	10	95	66	56.4	10
12	32	46	40	157	14	20/25	25	132	3xM6	150	52	52	136.3	M5x45	10	115	70	62.4	10
14	60	95	50	174	14	20/25/30	30	145	3xM8	165	60	60	150	M6x55	12	124	80	77.3	13
16	80	125	55	203	15	25/30/35/38	38	170	3xM8	190	70	70	174.5	M6x60	12	149	104	83.5	13.3

Size	M <sub>K</sub>	M <sub>K max.</sub>	H3	H4	H5	H6	H8	H9	H10	H11	H12	l1*	l2	S <sub>lü</sub> ± 0.1	S <sub>lü max at M<sub>K</sub></sub>	S <sub>lü max at M<sub>K max.</sub></sub>	m (kg)
06	4	6	18	45.3	107	15.8	15.8	53	52.4	1	49	6	400	0.2	0.6	0.4	1.1
08	8	12	20	54.8	118	16.3	16.3	64	64	1	59	9	400	0.2	0.6	0.45	1.9
10	16	23	20	61.4	142	27.4	27.4	79	77.3	1	74	12	400	0.2	0.7	0.5	3.8
12	32	46	25	67.4	162	29.4	29.4	89	88.3	1	84	12	400	0.3	0.8	0.5	5.7
14	60	95	30	83.3	201	33	33	100	99.7	1	94	14	400	0.3	0.8	0.5	8.6
16	80	125	30	89.5	250	37.4	37.5	116	114.8	1	108	14	600	0.3	0.9	0.6	12.0

\* Please contact the manufacturer if a different mounting surface made of steel is used.



# Double spring-operated brake INTORQ BFK457-06 ... 16

Low-noise design < 50 dbA

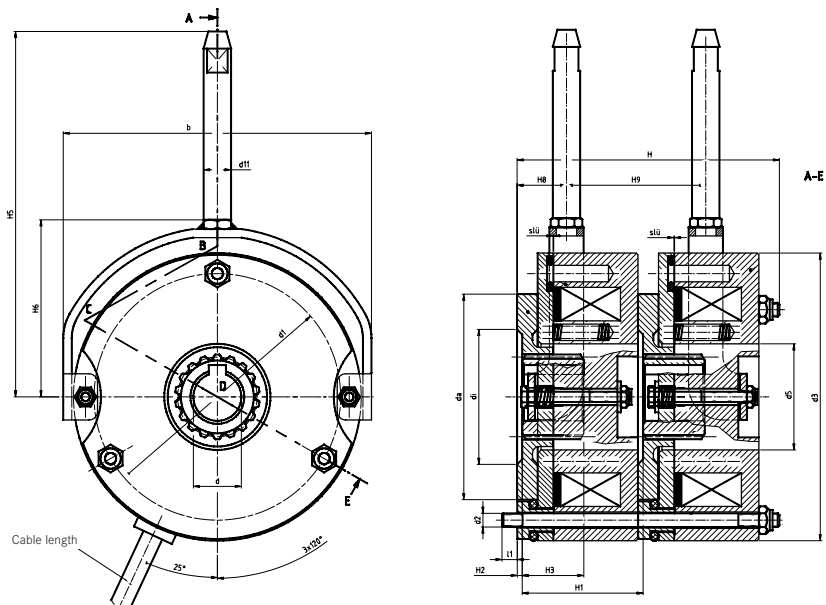

Size	M <sub>K</sub>	P <sub>20°</sub>	b	d <sub>J7</sub> pilot	d <sup>H7</sup> standard	d <sup>H7</sup> max.	d1	d2	d3	d5	d11	da	di	H	H1
06	2x4	20	90	10	11/12/14/15	15	72	3xM4	84	31	8	60	40	75.5	35.3
08	2x8	25	108	10	11/12/14/15/20	20	90	3xM5	102	41.5	8	77	47	90.5	42.8
10	2x16	30	137	10	15/20	20	112	3xM6	130	44	10	95	66	102.9	48.4
12	2x32	40	157	14	20/25	25	132	3xM6	150	52	10	115	70	114.7	54.4
14	2x60	50	174	14	20/25/30	30	145	3xM8	165	60	12	124	80	140.5	66.3
16	2x80	55	203	15	25/30/35/38	38	170	3xM8	190	70	12	149	104	153.1	72.5

Size	M <sub>K</sub>	H2	H3	H5	H6	H8	H9	I1*	I2	S <sub>lü</sub> ± 0.1	S <sub>lü</sub> max at M <sub>K</sub>	S <sub>lü</sub> max at M <sub>K</sub> max	m (kg)
06	2x4	1	18	109	54	13	44	6	400	0.2	0.5	0.4	1.9
08	2x8	1.5	20	121.7	62	12.7	63.3	9	400	0.2	0.5	0.45	3.2
10	2x16	2	20	147	84	16	70	11	400	0.2	0.5	0.5	6.4
12	2x32	2	25	166	93	18.3	78.4	11	400	0.3	0.75	0.5	9.8
14	2x60	2	30	186	106	22	91.5	14	400	0.3	0.75	0.5	14.8
16	2x80	2.25	30	230	120.5	24.5	100	14	600	0.3	0.75	0.6	21.0

\*Please contact the manufacturer if a different mounting surface made of steel is used.

## Features

- Basic design without flange
- Noise-reduced armature plate
- Noise-reduced aluminium rotor
- Easy to assemble due to the integrated fixing screws for direct mounting
- The brake is delivered in parts



# Order form for spring-operated brake INTORQ BFK457-□□

**Recipient: INTORQ GmbH & Co. KG**

Wülmser Weg 5, D-31855 Aerzen

Fax +49 (0)51 54/95 39-10

**Sender**

Company \_\_\_\_\_ Customer no. \_\_\_\_\_

Street/PO Box \_\_\_\_\_ Order no. \_\_\_\_\_

Postal code/City \_\_\_\_\_ Issued by \_\_\_\_\_

Delivery address\* \_\_\_\_\_ Telephone \_\_\_\_\_

\_\_\_\_\_ Telefax \_\_\_\_\_

Invoice recipient\* \_\_\_\_\_ Date of delivery \_\_\_\_\_

Date \_\_\_\_\_ Signature \_\_\_\_\_

\* Please state if different from sender.

**Order quantity INTORQ BFK457** \_\_\_\_\_ **Price/unit** \_\_\_\_\_

**Size**             01     02     03     04     05

**Compact:** Fully assembled with rotor and flange

06     08     10     12     14     16

**Basic:** Stator complete with rotor

**Compact:** Fully assembled with rotor and flange

**Noise-reduced** 2 x Basic in low-noise design

**Voltage**             24 V     205 V     42 V (sizes 14 and 16) (other voltages on request)

**Braking torque**

	01	02	03	04	05	06	08	10	12	14	16
<input type="checkbox"/>	0.12	0.25	0.5	1	2	4	8	16	32	60	80
<input type="checkbox"/>	0.24	0.5	1.0	2.0	4.0	6	12	23	46	90	125

**Manual release**     Assembled

**Hub**                    \_\_\_\_\_ Bore diameter in mm (see technical data, tables)

Prices in €/unit · For Germany: plus vat

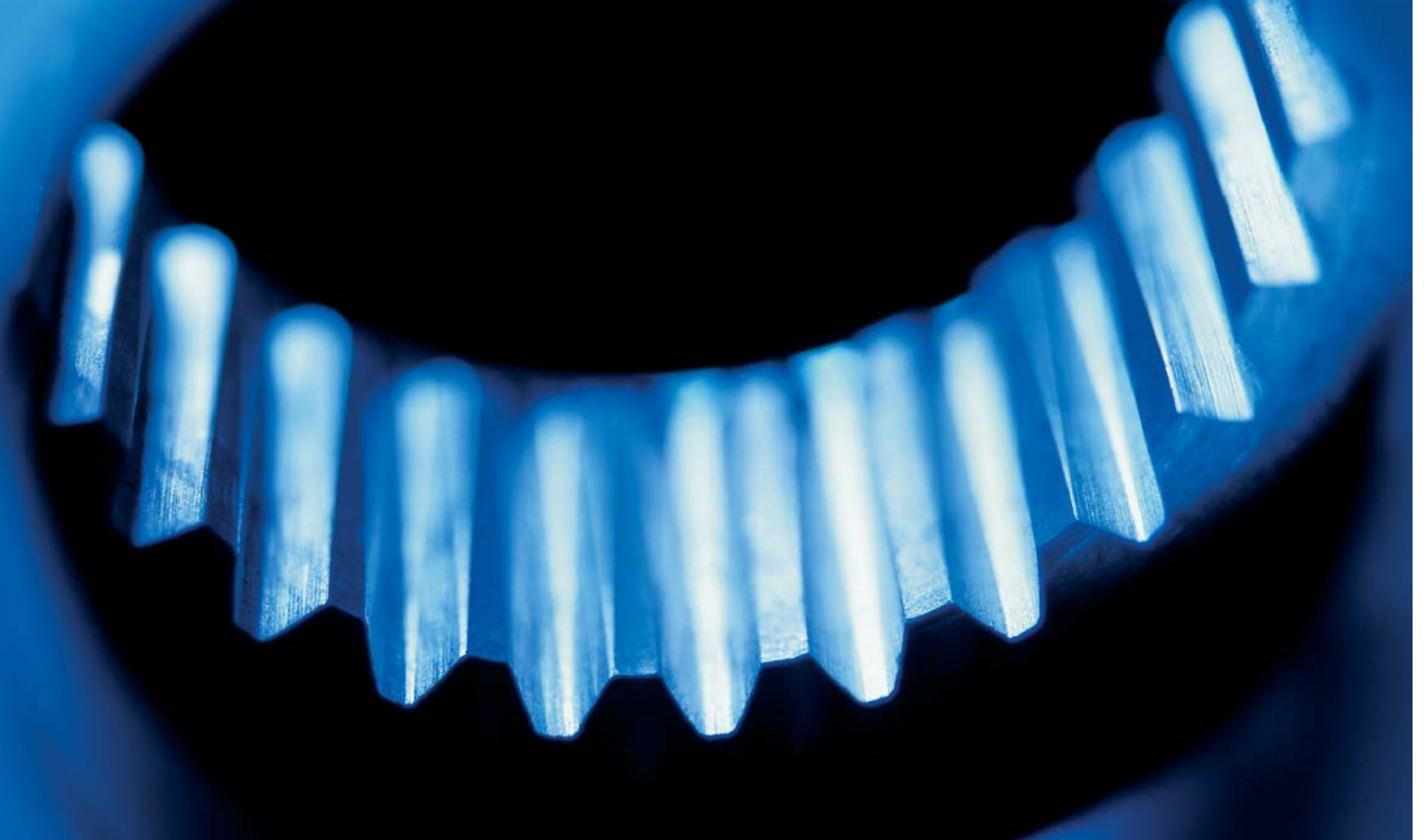

## INTORQ – Sales and Service around the world

Our customers can reach us at any time from anywhere in the world. We cooperate with Lenze's network of worldwide sales offices and service centres.

Our helpline (008000 24 46877) will provide you with expert advice, 24 hours a day, 365 days a year.

Information about our products, catalogues and Operating Instructions can be found at **[www.intorq.de](http://www.intorq.de)**

Contact the Lenze service centres and sales partners through the Lenze website **[www.Lenze.com](http://www.Lenze.com)**.



**INTORQ**

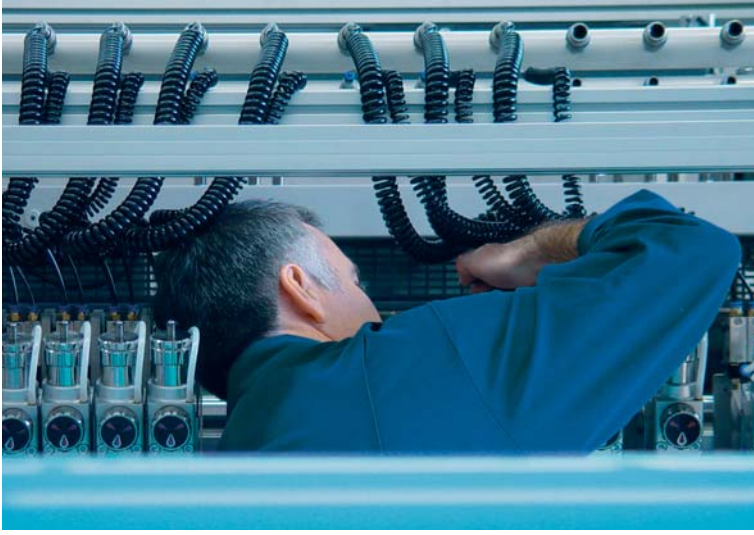

## Worldwide sales at [www.Lenze.com](http://www.Lenze.com)



- |                    |                     |
|--------------------|---------------------|
| Algeria            | Japan               |
| Argentina          | Latvia              |
| Australia          | Lithuania           |
| Austria            | Luxembourg          |
| Belgium            | Macedonia           |
| Bosnia-Herzegovina | Malaysia            |
| Brazil             | Mauritius           |
| Bulgaria           | Mexico              |
| Canada             | Morocco             |
| Chile              | Netherlands         |
| China              | New Zealand         |
| Croatia            | Norway              |
| Czech Republic     | Philippines         |
| Denmark            | Poland              |
| Egypt              | Portugal            |
| Estonia            | Romania             |
| Finland            | Russia              |
| France             | Serbia-Montenegro   |
| Germany            | Singapore           |
| Greece             | Slovak Republic     |
| Hungary            | Slovenia            |
| Iceland            | South Africa        |
| India              | South Korea         |
| Indonesia          | Spain               |
| Iran               | Sweden              |
| Israel             | Switzerland         |
| Italy              | Syria               |
|                    | Taiwan              |
|                    | Thailand            |
|                    | Tunisia             |
|                    | Turkey              |
|                    | Ukraine             |
|                    | United Kingdom/Eire |
|                    | USA                 |

**INTORQ**

**INTORQ GmbH & Co. KG**

Postfach 1103  
D-31849 Aenzen

Wülmser Weg 5  
D-31855 Aenzen

Phone +49 (0)51 54/95 39-01

Fax +49 (0)51 54/95 39-10

E-Mail [info@intorq.de](mailto:info@intorq.de)

[www.intorq.de](http://www.intorq.de)

**INTORQ**

setting the standard

[www.intorq.de](http://www.intorq.de)