

RCGH



RCGV

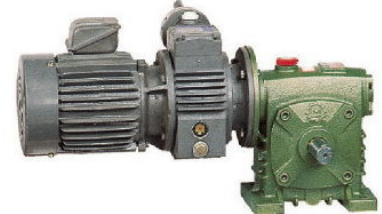

RCHW

**特點：****調速範圍大；速比高：**

變速機部變速比為1：6在4P60HZ馬達下，其轉速可為200~1200RPM，配合減速機可達1RPM。

Large Speed Regulating Range; High Reduction Ratio

The speed shifting mechanism with speed shifting ratio 1:6 at 4P60Hz can serve 200-1200 rpm and even down to 1 rpm while going with speed reducer.

可信賴的性能及較高的承受力：

特殊精密的構造，能夠承受衝擊負荷和反動作負荷，高效率運轉寧靜，維護容易。

Reliable Performance and High Loading Capability

Special precision structure provides high resistance to impact loading and reverse loading in addition to high efficient operation and easy maintenance.

操作注意：

1. 靜止時請勿調整速度
2. 全負荷情形請調至低速再起動
3. 勿超負荷使用

Operation Notices:

1. Do not regulate the speed under stop conditions.
2. For full loading condition, please regulate to low speed and restart.
3. Avoid overload operation.

變速機段效率曲線表

EFFICIENCY OF VARIATOR

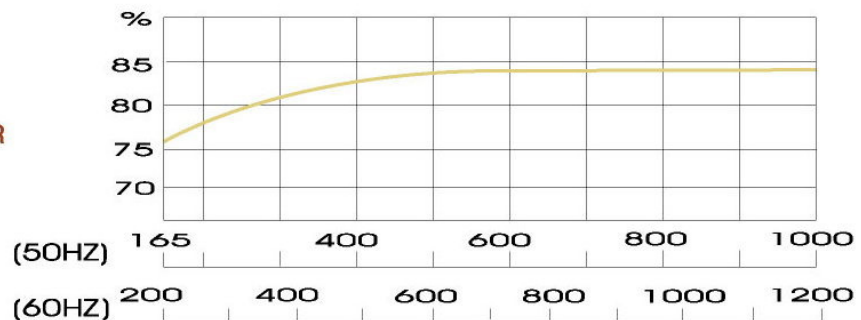

變速機段出力軸轉速表 VARIATOR SECTION OUTPUT RPM

出力軸轉速表 R.P.M OF THE OUTPUT SHAFT									
減速比 RATIO	1/5	1/10	1/15	1/20	1/25	1/30	1/40	1/50	1/60
4P 50HZ OUT RPM	33~200	16.5~100	11~66.67	8.25~50	6.6~40	5.5~33.3	4.125~25	3.3~20	2.75~16.67
4P 60HZ OUT RPM	40~240	20~120	13.33~80	10~60	8~48	6.67~40	5~30	4~24	3.33~20
減速比 RATIO	1/70	1/80	1/100	1/120	1/130	1/150	1/180	1/200	
4P 50HZ OUT RPM	2.36~14.29	2.06~12.5	1.65~10	1.38~8.33	1.27~7.69	1.1~6.66	0.92~5.56	0.83~5	
4P 60HZ OUT RPM	2.86~17.14	2.5~15	2~12	1.67~10	1.54~9.23	1.33~8	1.11~6.67	1~6	



減速機附無段變速系列 REDUCER WITH VARIATOR SERIES

■ 臥式減速機附無段變速

HORIZONTAL TYPE REDUCER WITH VARIATOR

■ MODEL : RCGH

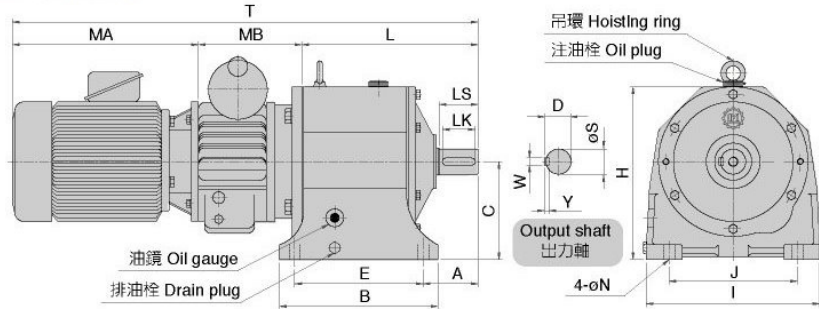

尺寸表 Dimension

單位 : m/m

型號 MODEL	馬力 HP (4P)	齒輪段減速比 GEAR RATIO	T	L	MA	MB	H	C	A	腳座 FOOT STOCK					出力軸 OUTPUT SHAFT					重量 Weight (KG)
										E	J	B	I	N	D	LS	WxYxLK	S		
★ 202	1/2	5 10	535	172	248	115	170	90	60	125	140	155	180	10	27	45	7x7x35	24	34	
203	1/2	10 15 20 25 30	543	180	248	115	190	110	62	135	145	167	190	13	27	45	7x7x35	24	37	
205	1	5 10 15 20 25 30	602	223	242	137	227	127	77	170	180	210	230	15	31	50	7x7x40	28	57	
206	2	5 10	723	228	322	173	227	127	80	170	180	210	250	15	35	55	10x8x45	32	80	
207	2	15 20 25 30	752	257	322	173	253	145	82	205	195	245	255	15	35	55	10x8x45	32	86	
208	3	5 10	785	262	315	208	265	145	87	205	195	245	255	15	41	60	10x8x50	38	120	
209	3	15 20 25 30	802	279	315	208	289	164	87	215	215	265	295	19	41	60	10x8x50	38	133	
210	5	5 10	863	284	371	208	289	164	92	215	215	265	295	19	45	65	12x8x55	42	150	
211	5	15 20 25 30	904	325	371	208	332	192	109	250	270	310	340	19	51	75	12x8x65	48	171	
212	7 1/2	5 10	948	325	374	249	332	192	109	250	270	310	340	19	51	75	12x8x65	48	251	
213	7 1/2	15 20 25 30	1011	388	374	249	385	210	126	310	310	380	410	22	60	80	15x10x70	56	288	
214	10	15 20 25 30	1054	393	412	249	385	210	131	310	310	380	410	22	66	85	15x10x75	62	301	
306	1/2	60 70 80 100 120	607	244	248	115	227	127	80	170	180	210	260	15	35	55	10x8x45	32	48	
308	1/2	130 150 180 200	631	268	248	115													55	
	1	40 50 60 70 80 100 120	638	259	242	137	253	145	87	205	195	245	255	15	41	60	10x8x50	38	65	
310	2	30 40	754		322	173													88	
	1	130 150 180 200	685	306	242	137													81	
	2	60 70 80 100 120	791	296	322	173	289	164	92	215	215	265	295	19	45	65	12x8x55	42	104	
312	3	30 40	819		315	208													137	
	2	130 150 180 200	842	347	322	173													128	
314	3	50 60 70 80 100 120	860	337	315	208	332	192	109	250	270	310	340	19	51	75	12x8x65	48	161	
	5	30 40 50	916		371	208													178	
	3	130 150 180 200	940		315	208													206	
315	5	60 70 80 100 120	996	417	371	208	385	210	131	310	310	380	410	22	66	85	15x10x75	62	223	
	7 1/2	30 40 50	1029	406	374	249													303	
316	5	130 150 180 200	1067		371	208													289	
	7 1/2	40 50 60 70 80 100 120	1111	488	374	249	445	245	157	360	360	440	460	25	76.5	100	20x12x90	72	369	
	10	30 40 50	1149		412	249													382	
316	10	40 50 60 70 80 100 120	1149	488	412	249	445	245	157	360	360	440	460	25	80.5	100	20x12x90	76	384	

※重量不含馬達 Motor weight exclusive ★表使用圓形外殼

■ 立式減速機附無段變速

VERTICAL TYPE REDUCER WITH VARIATOR

■ MODEL : RCGV

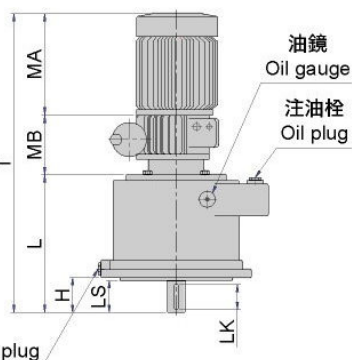
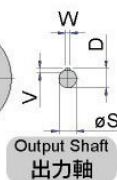
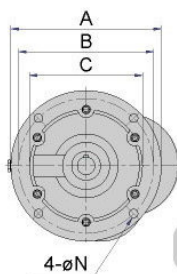

使用方向
Direction of Installation

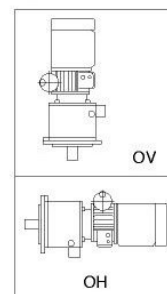

尺寸表 Dimension

單位：m/m

型號 MODEL	馬力 HP (4P)	齒輪段減速比 GEAR RATIO	MA	MB	L	T	H	法蘭面 FLANGE				出力軸 OUTPUT SHAFT				重量 Weight (KG)
								A	B	C	N	D	LS	S	WxYxLK	
★ 202	1/2	5 10	248	115	153	516	50	178	155	130	10	27	45	24	7x7x35	33
203	1/2	10 15 20 25 30	248	115	201	564	50	200	175	150	12	27	45	24	7x7x35	37
205	1	5 10 15 20 25 30	242	137	209	588	55	240	215	180	14	31	50	28	7x7x40	55
206	2	5 10	322	173	214	709	60	240	215	180	14	35	55	32	10x8x45	78
207	2	15 20 25 30	322	173	233	728	60	280	245	210	14	35	55	32	10x8x45	84
208	3	5 10	315	208	238	761	65	280	245	210	14	41	60	38	10x8x50	117
209	3	15 20 25 30	315	208	261	784	65	330	300	250	18	41	60	38	10x8x50	130
210	5	5 10	371	208	266	845	70	330	300	250	18	45	65	42	12x8x55	147
211	5	15 20 25 30	371	208	305	884	80	380	335	290	18	51	75	48	12x8x65	167
212	7 1/2	5 10	374	249	305	928	80	380	335	290	18	51	75	48	12x8x65	247
213	7 1/2	15 20 25 30	374	249	358	981	85	450	400	350	21	60	80	56	15x10x70	281
214	10	15 20 25 30	412	249	363	1024	90	450	400	350	21	66	85	62	15x10x75	294
306	1/2	60 70 80 100 120	248	115	234	597	60	240	215	180	14	35	55	32	10x8x45	49
308	1/2	130 150 180 200	248	115	246	609										52
	1	40 50 60 70 80 100 120	242	137		625	65	280	245	210	14	41	60	38	10x8x50	62
	2	30 40	322	173	238	733										85
310	1	130 150 180 200	324	137	279	658										80
	2	60 70 80 100 120	322	173		774	70	330	300	250	18	45	65	42	12x8x55	103
	3	30 40	315	208	269	792										136
312	2	130 150 180 200	322	173	325	820										124
	3	50 60 70 80 100 120	315	208		848	80	380	335	290	18	51	75	48	12x8x65	157
	5	30 40	371	208	315	894										174
314	3	130 150 180 200	315	208	387	910										197
	5	60 70 80 100 120	371	208		966	90	450	400	350	21	66	85	62	15x10x75	214
	7 1/2	30 40 50	374	249	366	989										294
315	5	130 150 180 200	371	208		1031										270
	7 1/2	60 70 80 100 120	374	249	452	1075	105	500	450	400	24	76.5	100	72	20x12x90	350
	10	30 40 50	412	249		1113										363
316	10	60 70 80 100 120	412	249	452	1113	105	500	450	400	24	80.5	100	76	20x12x90	364

※重量不含馬達 Motor weight exclusive ★表使用圓形外殼



減速機附無段變速系列

GEAR REDUCER WITH VARIATOR SERIES

■ 蝸輪減速機附無段變速

WORM REDUCER WITH VARIATOR

■ MODEL : RCHW

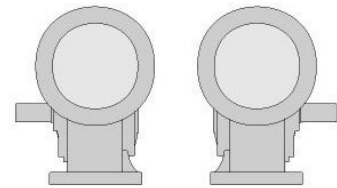
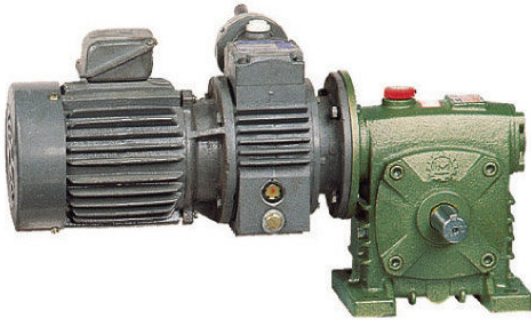

L R

軸向選擇 Shaft Direction

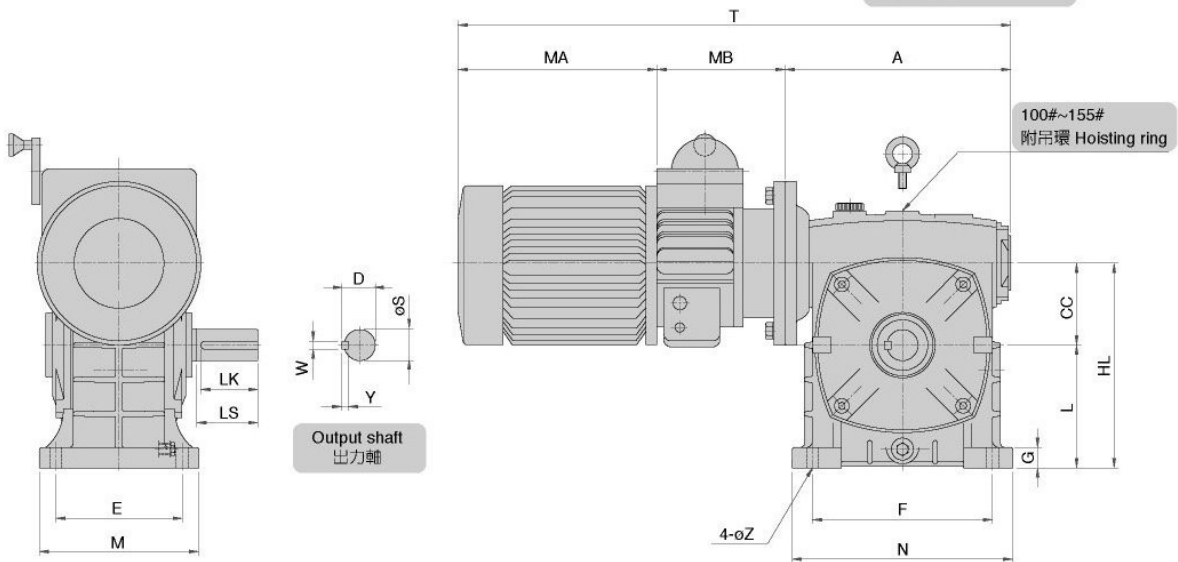

尺寸表 Dimension

單位 : m/m

減速比 RATIO			腳座 FOOT STOCK							出力軸 OUTPUT SHAFT				重量 Weight (KG)						
型號 MODEL	馬力 HP		A	MA	MB	CC	HL	L	T	E	F	M	N		G	Z	LS	D	S	WxYxLxK
	1/10~1/30	1/40~1/60																		
50	1/4		154	225	100	50	130	80	479	95	110	120	140	15	11	40	19	17	5x5x35	20
60	1/2	1/4	167	225	100	60	150	90	492	105	120	130	150	20	11	50	25	22	7x7x45	37
			248	115	530															
70	1	1/2	200	248	115	70	175	105	563	115	150	150	190	20	15	60	31	28	7x7x55	50
			242	137	579															
80	2	1	223	242	137	80	200	120	602	135	180	170	220	20	15	65	35	32	10x8x60	86
			322	173	718															
100	3	2	278	322	173	100	250	150	773	155	220	195	270	25	15	75	41	38	10x8x70	133
			315	208	801															
120	5	3	323	315	208	120	300	180	846	180	260	230	320	30	18	85	48	45	12x8x80	173
			371	208	902															
135	7 1/2	5	369	371	208	135	350	215	948	200	290	250	350	32	18	95	59	55	15x10x90	275
			374	249	992															
155	10	7 1/2	407	374	249	155	390	235	1030	220	320	280	390	38	20	110	64	60	15x10x105	336
			412	249	1068															

GEAR REDUCER WITH BELT-VARIATOR SERIES

皮帶式無段變速系列

MODEL : GRV



▲GRV-H



▲GRV-V

MODEL : WRV



▲WRV-H



▲WRV-V

機種、形式表示 (DESCRIPTION OF TYPE)

GRV-H 機型 TYPE	203 型號 MODEL	1/2 馬力 HP	20 速比 RATIO	V 方向 Installation Direction	L 方向 Shaft Direction
----------------------------	---------------------------	------------------------	--------------------------	--	-----------------------------------

特點：

- 安裝方便，客戶只需4孔基準孔即可。
- 體積小、組合角度，多種變化。
- 應用範圍廣、安裝容易、簡單。
- 密閉式、防塵、安全、易保養。
- 可承受較大衝擊力作業。(GRV)
- 特殊高速減速比。(GRV)

Belt Specifications and of Shaft Spacing Reference Table Features:

- Easy to install. Only four base holes for anchor bolts are required.
- Small size and multiple assembly angles.
- Wide applications; easy installation.
- Enclosed type; dust-proof, safe, and easy to maintain.
- Resistant to heavy shock loads. (GRV)
- High reduction ratio. (GRV)

皮帶規格與軸間距離參考表

馬力 HP (4P)	型號 MODEL GRV	型號 MODEL WRV	軸間距 CENTER DISTANCE	皮帶規格 BELT MODEL	皮帶減速比 BELT RATIO
1/4	201	50 60	163	1022V220	1:4
	202		163	1422V270	1:4
1/2	203	60	200	1422V270	1:3.5
	205	70			
	306	70			
1	(205)	70 80	211	1422V300	1:4
	308		250	1422V330	1:4
2	206		250	1422V330	1:4
	207	80 100	235	1922V338	1:4
3	208	100	280	31x975	1:4
	209	100			
	312	120			
5	210		293	41x14x1063	1:4
	211 312	120			

出力軸轉速參考表 Output RPM for Reference

馬力 HP 減速比 RATIO	1/4HP		1/2HP		1HP		2HP		3HP		5HP	
	50Hz	60Hz	50Hz	60Hz	50Hz	60Hz	50Hz	60Hz	50Hz	60Hz	50Hz	60Hz
1/10	50~200	60~240	75~265	90~318	60~250	72~300	53~215	64~258	48~192	57~228	48~192	57~228
1/15	33~132	40~160	50~176	60~212	40~166	48~200	36~143	43~174	36~144	42.5~171	36~144	42.8~171
1/20	25~100	30~120	38~132	45~159	30~125	36~150	27~107	32~129	24~96	28.5~114	24~96	28.5~114
1/30	17~68	20~80	25~88	30~106	20~83	24~100	18~71	22~86	16~64	19~76	16~64	19~76
1/40	12.5~50	15~60	19~66	23~79	15~62	18~75	14~53	16~64	12~48	14.3~57	12~48	14.3~57
1/50	10~40	12~48	15~53	18~63	12~50	15~60	11~43	13~51	9.6~28.4	11.4~45.6	9.6~28.4	11.4~45.6
1/60	8.5~34	10~40	13~44	15~53	10~41	12~50	9~35	11~43	8~32	9.5~38	8~32	9.5~38



皮帶式無段變速系列

GEAR REDUCER WITH BELT-VARIATOR SERIES



- 齒輪減速機附無段變速
GEAR REDUCER WITH VARIATOR
- MODEL : GRV-H

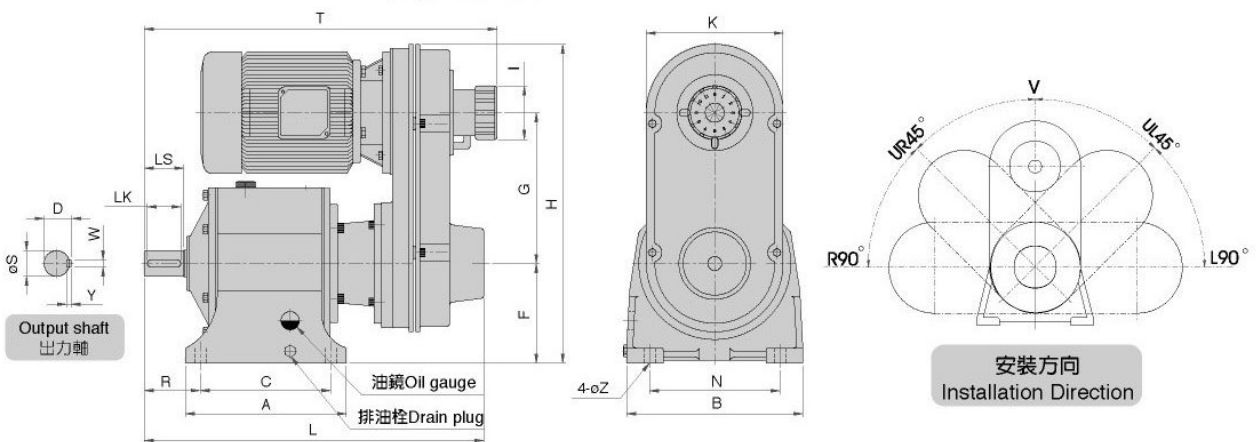

尺寸表 Dimension

單位 : m/m

馬力 HP (4P)	型號 MODEL	減速比 RATIO	K	F	G	H	I	L	T	R	腳座 FOOT STOCK				出力軸 OUTPUT SHAFT				重量 Weight (KG)	
											A	B	C	N	Z	LS	S	D		WxYxLK
1/4	★GRV-H201	5 10 15 20 25 30	185	90	162	345	70	331	381	53	155	180	125	140	10	38	19	21	5x5x33	24
	★GRV-H202	5 10	185	90	200	383	86	338	376	60	155	180	125	140	10	45	24	27	7x7x40	26
1/2	GRV-H203	15 20 25 30	185	110	200	403	86	377	415	62	170	195	135	145	13	45	24	27	7x7x40	29
	GRV-H205	40 50	185	127	200	420	86	429	467	77	210	230	170	180	15	50	28	31	7x7x45	41
1	GRV-H306	60 80 100 120	185	127	200	420	86	452	490	80	210	230	170	180	15	55	32	35	10x8x50	42
	GRV-H205	5 10 15 20 25 30	225	127	212	452	86	479	502	77	210	230	170	180	15	50	28	31	7x7x45	52
2	GRV-H308	40 50 60 80 100 120	228	145	248	505	86	516	539	87	245	255	205	195	15	60	38	41	10x8x55	60
	GRV-H206	5 10	225	127	248	488	86	484	519	80	210	230	170	180	15	55	32	35	10x8x50	63
3	GRV-H207	15 20 25 30	265	145	230	508	86	548	583	82	245	255	205	195	15	55	32	35	10x8x50	69
	★GRV-H208	5 10	265	145	280	558	86	551	586	87	245	255	205	195	15	60	38	41	10x8x55	80
5	GRV-H209	15 20 25 30	265	164	280	577	86	570	605	88	265	295	215	215	19	60	38	41	10x8x55	93
	GRV-H312	40 50 60 80 100 120	265	192	280	610	86	629	664	109	315	345	250	270	19	75	48	51	12x8x70	125
7 1/2	GRV-H210	5 10	290	164	290	599	86	579	609	92	265	295	215	215	19	65	42	45	12x8x60	109
	GRV-H211	15 20 25 30	290	192	290	627	86	621	651	109	310	340	250	270	19	75	48	51	12x8x70	130
7 1/2	GRV-H312	40 50 60	290	192	290	627	86	633	663	109	310	340	250	270	19	75	48	51	12x8x70	137
	GRV-H212	5 10	340	192	457	815	200	725	748	109	310	340	250	270	19	75	48	51	12x8x70	187
7 1/2	GRV-H213	15 20 30	340	210	457	833	200	788	811	131	380	410	310	310	22	80	56	60	15x10x75	224
	GRV-H314	35 40 50	340	210	457	833	200	795	818	131	380	410	310	310	22	85	62	66	15x10x80	239

※重量不含馬達 Motor weight exclusive ★表使用圓形外殼



GEAR REDUCER WITH BELT-VARIATOR SERIES

皮帶式無段變速系列



齒輪減速機附無段變速

GEAR REDUCER WITH VARIATOR

MODEL : GRV-V

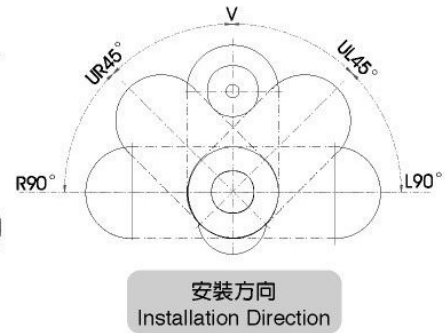
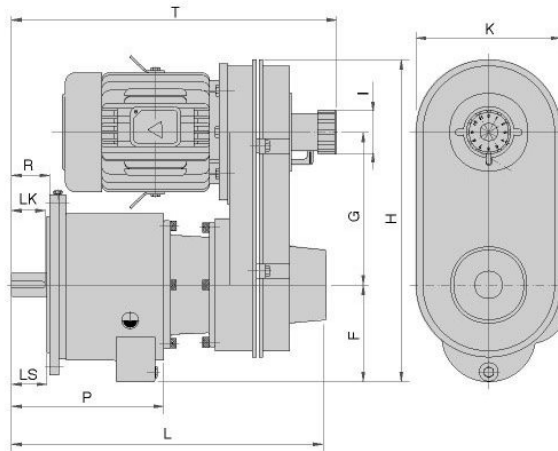
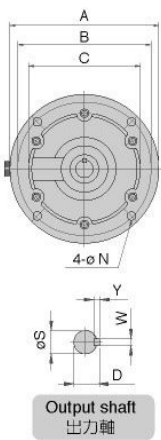

尺寸表 Dimension

單位 : m/m

馬力 HP (4P)	型號 MODEL	減速比 RATIO	K	F	G	H	I	L	T	P	R	法蘭面 FLANGE				出力軸 OUTPUT SHAFT				重量 Weight (KG)
												A	B	C	N	LS	S	D	WxYxLK	
1/4	GRV-V201	5 10 15 20 25 30	185	105	162	360	70	313	363	145	43	178	155	130	10	38	19	21	5x5x33	21
	GRV-V202	5 10	185	105	162	360	86	320	358	153	50	178	155	130	10	45	24	27	7x7x40	25
1/2	GRV-V203	15 20 25 30	185	123	200	413	86	399	437	201	50	200	175	150	12	45	24	27	7x7x40	29
	GRV-V205	40 50	185	145	200	438	86	416	454	209	55	242	215	180	14	50	28	31	7x7x45	37
1	GRV-V306	60 80 100 120	185	145	200	438	86	424	462	234	60	242	215	180	14	55	32	35	10x8x50	41
	GRV-V205	5 10 15 20 25 30	225	145	212	470	86	466	489	209	55	242	215	180	14	50	28	31	7x7x45	50
2	GRV-V308	40 50 60 80 100 120	228	165	248	524	86	494	517	238	65	280	245	210	14	60	38	41	10x8x55	57
	GRV-V206	5 10	225	145	248	504	86	471	506	214	60	242	215	180	14	55	32	35	10x8x50	61
3	GRV-V207	15 20 25 30	265	165	230	528	86	526	561	233	60	280	245	210	14	55	32	35	10x8x50	67
	GRV-V208	5 10	265	165	280	578	86	529	564	238	65	280	245	210	14	60	38	41	10x8x55	77
5	GRV-V209	15 20 25 30	265	185	280	598	86	552	587	261	65	330	300	250	18	60	38	41	10x8x55	90
	GRV-V312	40 50 60 80 100 120	265	215	280	628	86	606	641	315	80	380	335	290	18	75	48	51	12x8x70	117
7 1/2	GRV-V210	5 10	290	185	290	620	86	561	591	266	70	330	300	250	18	65	42	45	12x8x60	106
	GRV-V211	15 20 25 30	290	215	290	650	86	600	630	305	80	380	335	290	18	75	48	51	12x8x70	126
7 1/2	GRV-V312	40 50 60	290	215	290	650	86	610	640	315	80	380	335	290	18	75	48	51	12x8x70	133
	GRV-V212	5 10	340	200	457	728	200	705	728	305	80	380	335	290	18	75	48	51	12x8x70	183
7 1/2	GRV-V213	15 20 25 30	340	230	457	781	200	758	781	358	85	450	400	350	21	80	56	60	15x10x75	220
	GRV-V314	35 40 50	340	230	457	789	200	766	789	366	90	450	400	350	21	85	62	66	15x10x80	235

※重量不含馬達 Motor weight exclusive





皮帶式無段變速系列

GEAR REDUCER WITH BELT-VARIATOR SERIES

■ 蝸輪減速機附無段變速

WORM GEAR REDUCER WITH VARIATOR

■ MODEL : WRV-H

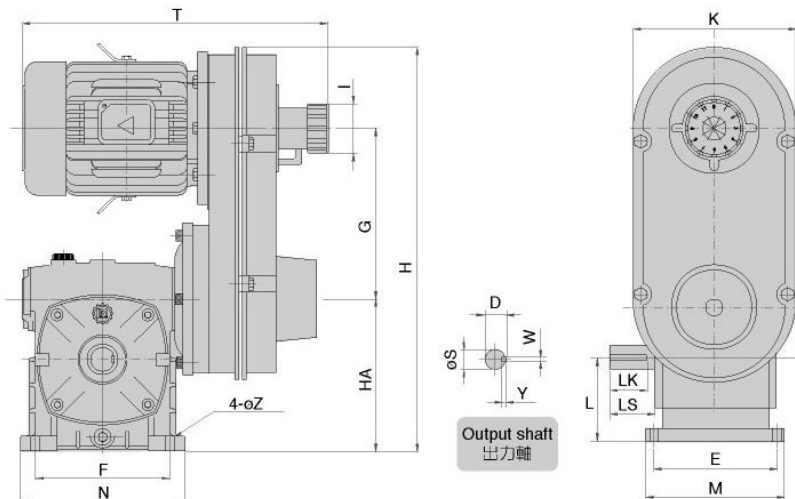
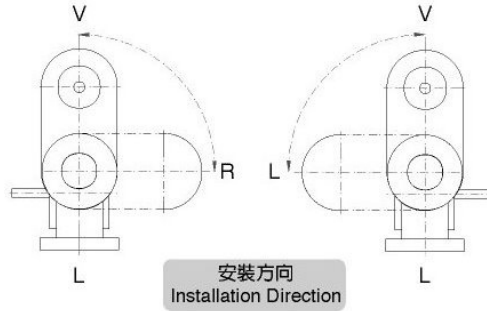
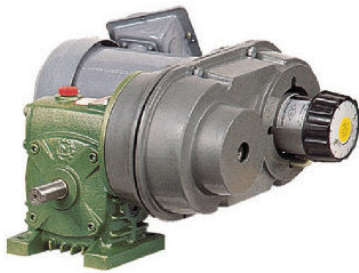

尺寸表 Dimension

單位 : m/m

型號 MODEL	減速比 RATIO	馬力 HP (4P)	L	I	K	T	HA	G	H	腳座 FOOT STOCK					出力軸 OUTPUT SHAFT				重量 Weight (KG)
										N	M	F	E	Z	S	D	LS	WxYxLK	
WRV-H50	10	1/4	80	70	185	375	130	162	385	143	121	110	95	11	17	19	40	5x5x35	23
		1/4	90	86	185	405	150	162	405	154	133	120	105	11	22	25	50	7x7x45	25
WRV-H60	20	1/2	105	86	185	405	175	200	468	195	152	150	115	15	28	31	60	7x7x55	32
		1	120	86	225	415	200	212	500	221	172	180	135	15	32	35	65	10x8x60	45
WRV-H70	30	1	120	86	225	415	200	212	525	221	172	180	135	15	32	35	65	10x8x60	58
		2	150	86	265	536	250	230	563	270	195	220	155	15	38	41	75	10x8x70	69
WRV-H80	40	2	150	86	265	536	250	230	613	270	195	220	155	15	38	41	75	10x8x70	83
		3	180	86	285	515	250	280	663	325	232	260	180	18	45	48	85	12x8x80	93
WRV-H100	50	3	180	86	285	515	250	280	713	325	232	260	180	18	45	48	85	12x8x80	116
		5	180	86	285	565	300	290	735	325	232	260	180	18	45	48	85	12x8x80	132

※重量不含馬達 Motor weight exclusive



GEAR REDUCER WITH BELT-VARIATOR SERIES

皮帶式無段變速系列

■ 蝸輪減速機附無段變速

WORM GEAR REDUCER WITH VARIATOR

■ MODEL : WRV-V

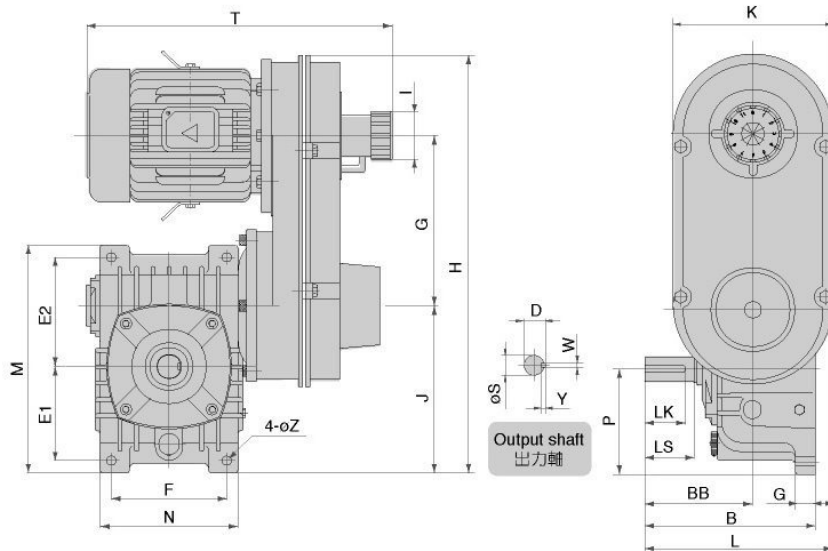
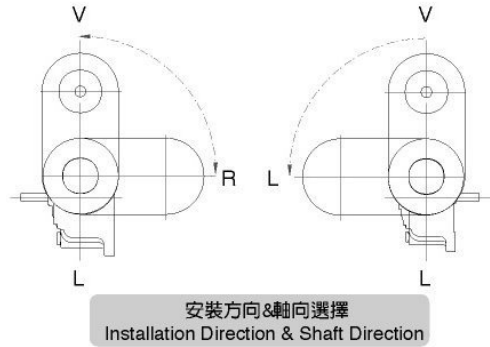

尺寸表 Dimension

單位 : m/m

型號 MODEL	減速比 RATIO	馬力 HP (4P)	P	I	K	T	J	G	H	BB	B	L	腳座 FOOT STOCK						出力軸 OUTPUT SHAFT				重量 Weight (KG)	
													N	F	E1	E2	M	G	Z	S	D	LS		WxYxLK
WRV-V50	10	1/4	107	70	185	375	157	162	412	98	148	191	120	90	93	102	221	16	11	17	19	40	5x5x35	21
		1/4	125	86	185	405	185	162	440	110	165	204	130	100	105	120	263	18	11	22	25	50	7x7x45	24
WRV-V60	20	1/2	142	86	185	405	212	200	505	130	195	223	160	120	120	135	297	19	15	28	31	60	7x7x55	33
		1	152	86	225	415	212	212	537	140	210	243	180	140	130	150	322	20	15	32	35	65	10x8x60	46
WRV-V70	30	1	152	86	265	536	232	230	595	170	260	253	230	190	155	180	380	30	15	38	41	75	10x8x70	53
		2	177	86	280	515	277	280	690	190	290	273	266	220	185	215	452	30	18	45	48	85	12x8x80	64
WRV-V80	40	2	211	86	280	565	331	280	744	190	290	302	230	190	155	180	380	30	15	38	41	75	10x8x70	80
		3	211	86	280	565	331	290	766	190	290	336	266	220	185	215	452	30	18	45	48	85	12x8x80	90
WRV-V100	50	3	211	86	280	565	331	280	744	190	290	326	266	220	185	215	452	30	18	45	48	85	12x8x80	113
		5	211	86	280	565	331	290	766	190	290	336	266	220	185	215	452	30	18	45	48	85	12x8x80	129

※重量不含馬達 Motor weight exclusive



齒輪減速機一般故障原因及改善方法

故障情形 FAULT DESCRIPTION	故障原因 REASONS	解決方法 SOLUTIONS
減速機過熱 Overheating	<ul style="list-style-type: none"> * 超負荷運轉 * 油封過度磨擦 * 出力軸與傳動裝置連接不當 * 衝擊荷重大 * Overload. * Over friction of oil seal. * Improper connection between driving shaft and the transmission device. * Large impact loading. 	<ul style="list-style-type: none"> * 調整至適當負荷 * 在油封處滴潤滑油 * 調整至適當位置 * 更換較大型號減速機 * Adjust to proper loading. * Drop lubricant at oil seal. * Adjust to proper position. * Use larger reduction gears.
減速機雜音 Noise	<ul style="list-style-type: none"> * 超負荷運轉 * 軸承損傷或間隙過大 * 潤滑油不足或劣化 * 出力軸與傳動裝置連接不當 * 螺絲鬆脫 * 傳動裝置固定不良 * Overload. * Bearing damaged or too large clearance. * Lubricant oil shortage or deterioration. * Improper connection between driving shaft and the transmission device. * Bolt loose. * Improper installation of transmission device. 	<ul style="list-style-type: none"> * 調整至適當負荷 * 更換軸承 * 依指示加入適量潤滑油 * 調整至適當位置 * 旋緊螺絲 * 傳動裝置固定 * Adjust to proper loading. * Replace bearing. * Fill in adequate lubricant oil as indication. * Adjust to proper position. * Tighten bolt. * Fix transmission device properly.
漏油 Oil leakage	<ul style="list-style-type: none"> * 油封損傷 * 油量過多 * 螺絲鬆脫 * 外殼破裂 * Oil seal damaged. * Too much oil. * Screw loose. * Outside shell fractured. 	<ul style="list-style-type: none"> * 更換油封 * 依指示加入適量潤滑油 * 旋緊螺絲 * 更換外殼 * Replace oil seal. * Fill in adequate lubricant oil as indication. * Tighten screw. * Replace outer shell.
出力軸不轉 Driving shaft cannot rotate	<ul style="list-style-type: none"> * 超負荷運轉 * 軸承損傷 * 異物嵌入 * 齒輪磨損 * 馬達損壞 * 配線錯誤 * 衝擊荷重過大 * Overload. * Bearing damaged. * Invasion by foreign objects. * Gear worn-out. * Motor out of order. * Incorrect wiring. * Large impact loading. 	<ul style="list-style-type: none"> * 調整至適當負荷 * 更換軸承 * 取出異物 * 更換齒輪 * 修復馬達 * 依指示配線 * 更換較大型號減速機 * Adjust to proper loading. * Replace bearing. * Take out foreign objects. * Replace gear. * Repair motor. * Wiring as indication. * Use larger reduction gears.

* 以上所列為一般故障原因，如有其它故障情形時，請與本公司連絡，我們將會提供最正確之服務。

The above items are general fault descriptions. In case of other kinds of faults, please contact with us to obtain most correct services.