

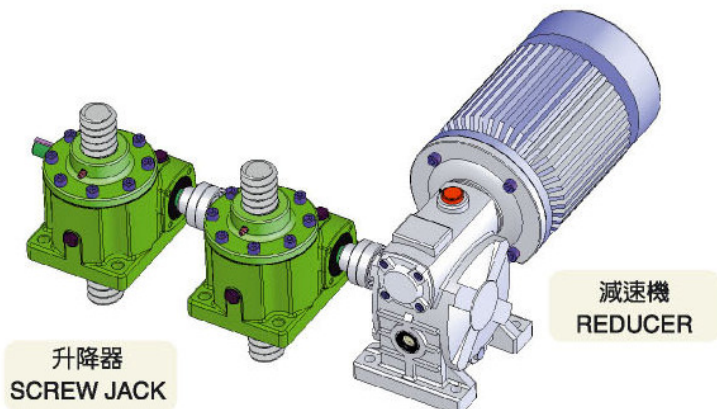

螺旋升降器與轉向器應用範例

EXAMPLES OF APPLICATION

■ I-TYPE



■ T-TYPE

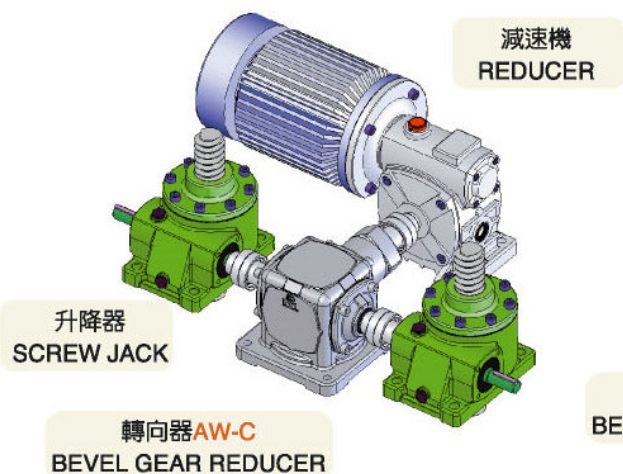

■ MODIFIED T-TYPE 變化式

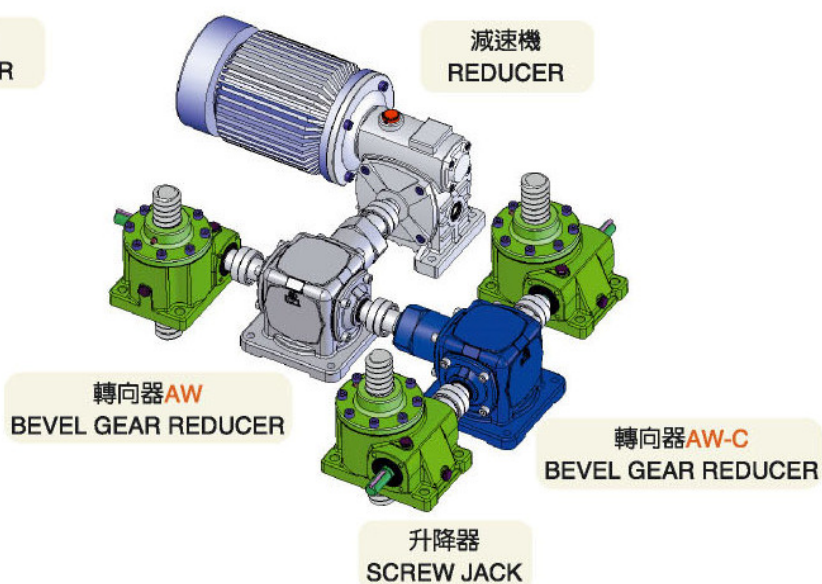

■ U-TYPE



■ H-TYPE



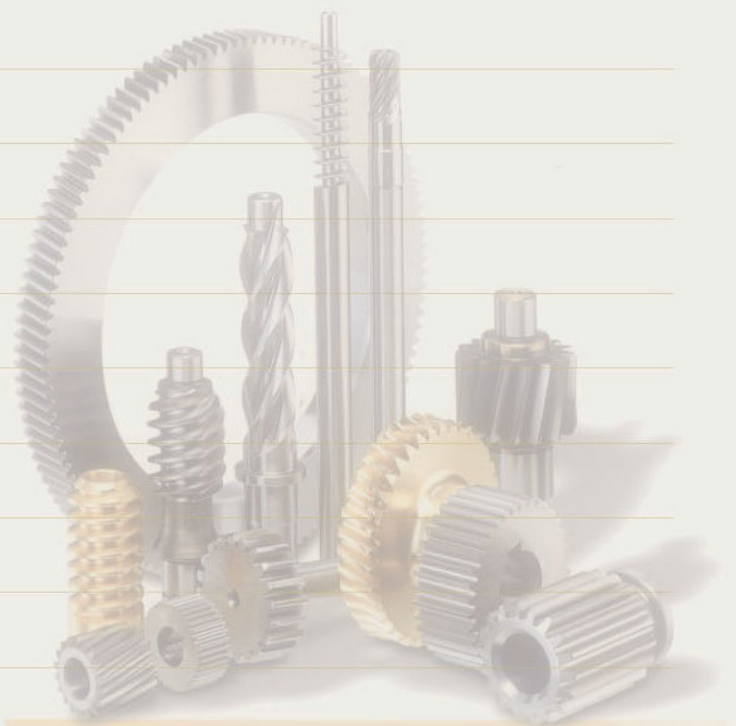



螺旋傘齒輪轉向器系列

BEVEL GEAR REDUCER SERIES

特性FEATURES :

1. 採用全系列模組化組合設計製造，低噪音、高轉矩、高效率。
2. 螺旋傘齒輪可簡單裝置於任何機械場所，方向可由客戶自行選擇上、下、左、右24種變化。
3. 齒輪傳動效率可達95%，速比分為1:1、1:2兩種。

1. All series are made of modulated design and production, low noise, high torque, high efficiency.
2. Bevel gear reducer can be installed at all machinery, 24 various directions are basis of up, down, left and right.
3. Gear transmission efficiency is available to 95%, ratio 1:1 or 1:2 can be choose.

機種型號表示 INDICATION OF MODEL NUMBERS

LM - TH - 15 - I - AW

公司代號 Company Name	機型 Type	型號 Model	速比 Ratio	軸向 Shaft Direction
		15	1/1	AW
		19	1/2	BW
		25		CW
		40		DW

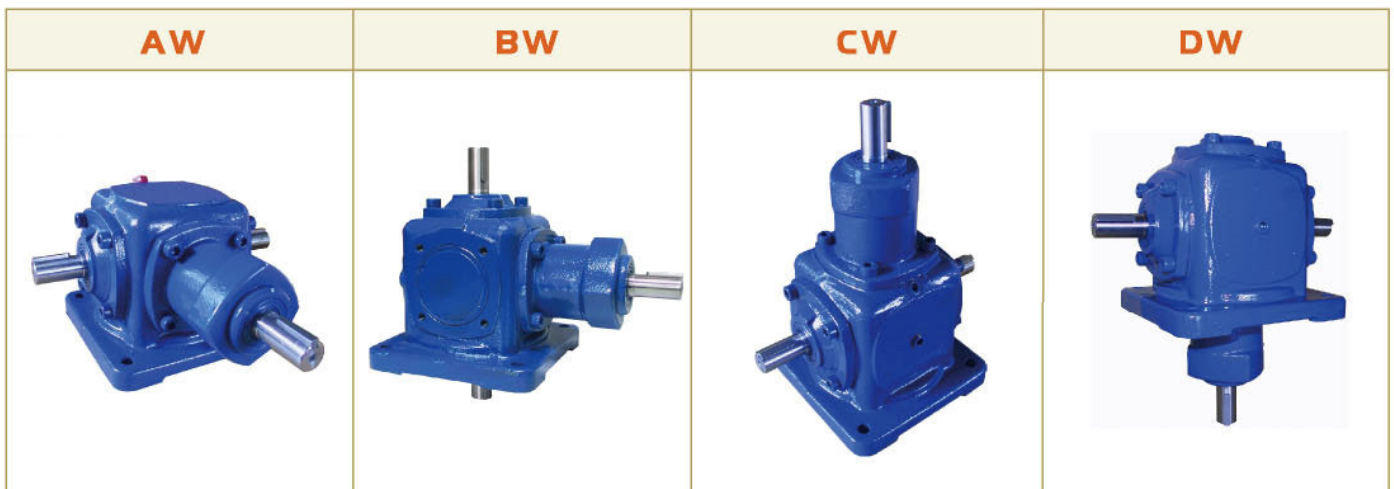

■ TH分解系統圖

■ SYSTEM DRAWING OF MODEL TH

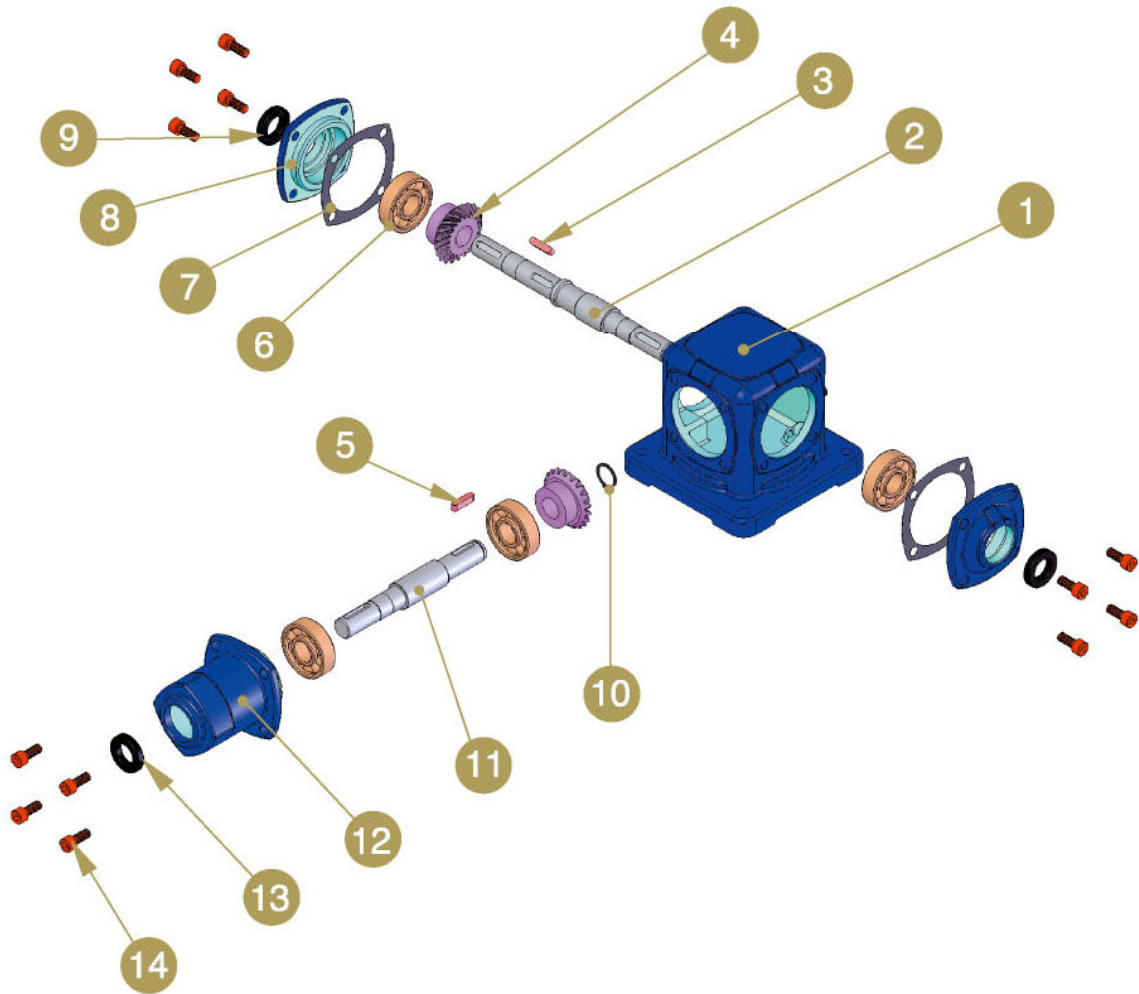

NO.	名稱	NAME OF PARTS	NO.	名稱	NAME OF PARTS
1	齒輪箱	Gear Shell	9	油封TC	Oil Seal TC
2	出力軸	Output Shaft	10	扣環	Snap Ring
3	雙圓鍵	Key	11	入力軸	Input Shaft
4	傘齒輪	Bevel Gear	12	入力軸蓋	Input Shaft Cover
5	雙圓鍵	Key	13	油封SC.TC	Oil Seal SC & TC
6	滾珠軸承	Ball Bearing	14	內六角承窩螺絲	HEX. Screw
7	非石棉墊片	Paper Packing			
8	出力軸蓋	Output Shaft Cover			



螺旋傘齒輪轉向器系列 BEVEL GEAR REDUCER SERIES

■ 結構、特性與應用 ■ STRUCTURE, FEATURES AND APPLICATION

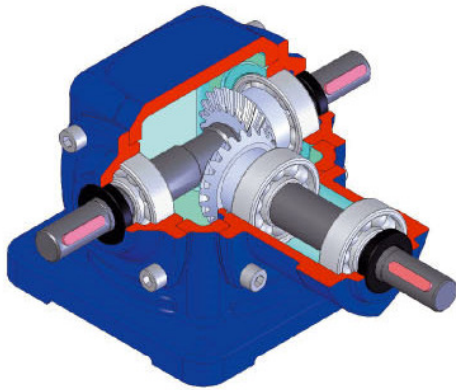

機殼：高剛性FC鑄鐵鑄造。
齒輪：齒輪採用優質高純淨度合金鋼SCM21滲碳硬化處理。
主軸：軸類採用中碳鋼S45C，高載重負荷能。
軸承：配置帶重負荷能力的滾珠軸承。
油封：雙封唇片的油封，兼具防塵及防漏油。

CASING: High rigid FC cast iron.
GEAR: Made of superior purity alloy steel SCM21 with carbonized heat treatment to increase hardness.
SHAFT: Made of steel S45C to bear high loading.
BEARING: Equipped with ball bearing.
OIL SEAL: With double lips to prevent dust and oil leakage.

轉向器基本轉動方式

BASIC ROTATION DIRECTION

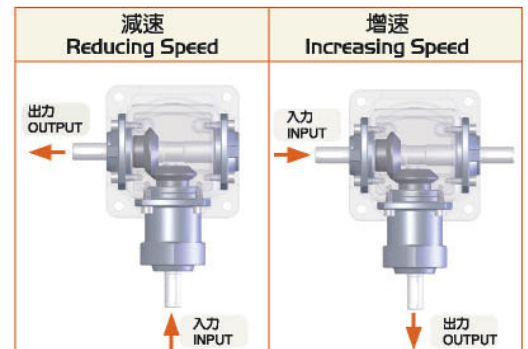
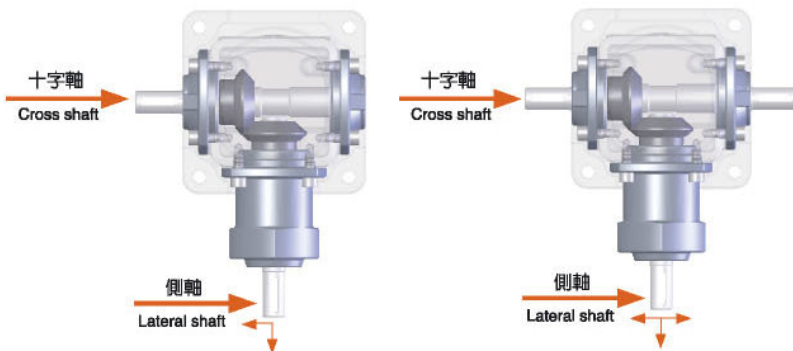

轉向器應用例

EXAMPLE

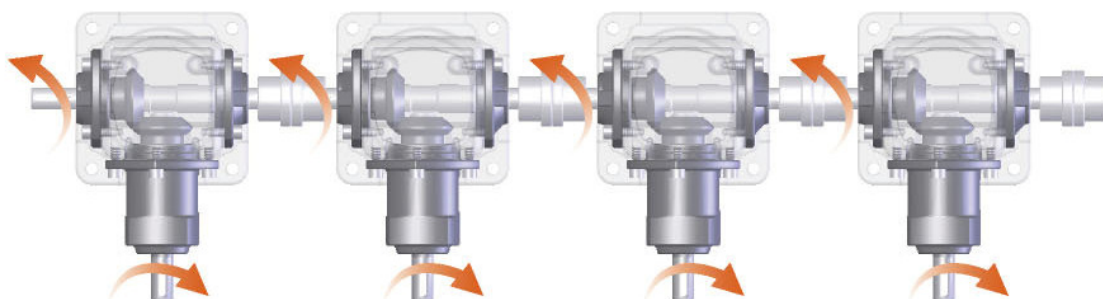







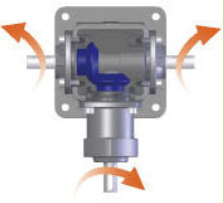
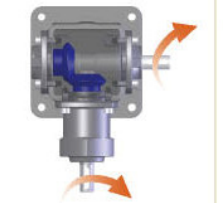
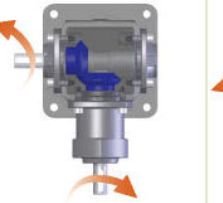
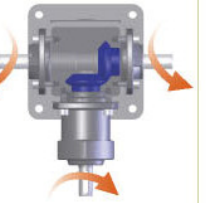
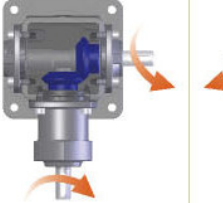

注意事項NOTE：

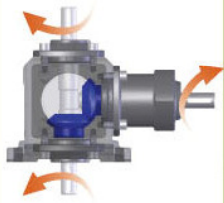
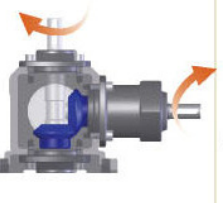
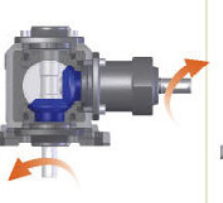
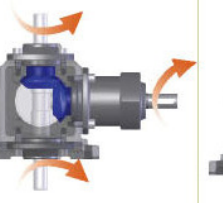
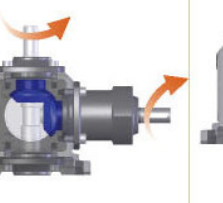
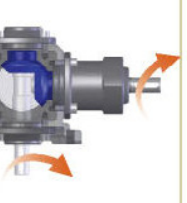
1. 正確選擇，選擇轉向代號及比數。
 2. 選擇油類，請先註明加潤滑脂或極壓機油。
 3. 如須特殊規格，請電洽。
- 1.To choose correct rotating direction and ratio.
2.To choose oil: Grease or KUO-KUANG brand oil HD-460 lubricant.
3.If you have special request, please contact us.

■ 軸向及旋向選擇表

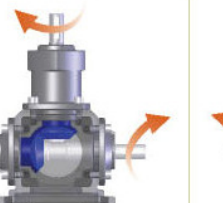
■ SHAFT & ROTATING DIRECTION

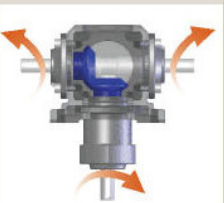
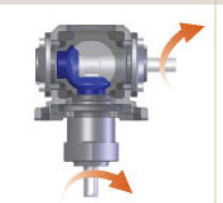
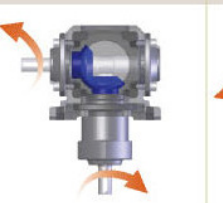
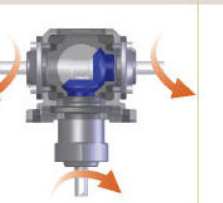
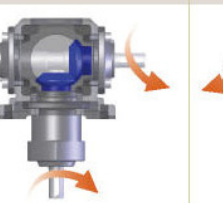
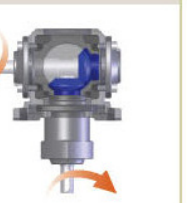
AW	AR	AL	AW-C	AR-C	AL-C
					
BW	BR	BL	BW-C	BR-C	BL-C
					
CW	CR	CL	CW-C	CR-C	CL-C
					
DW	DR	DL	DW-C	DR-C	DL-C
					

■ 潤滑油使用

■ LUBRICANT

適當的潤滑油使用，可以發揮轉向機的效率，並提高其運轉的壽命。

1. 本產品潤滑油採用中國石油-極壓機油HD460。
2. 只做短時間的運轉時，可以選擇使用潤滑脂。
3. 長期使用，每一年或2400小時更換一次潤滑油。

To use appropriate lubricant will enhance the efficiency of bevel gear reducer and increase its service life.

1. LI MING bevel gear reducers use KUO-KUANG brand oil HD-460.
2. Grease can be choosed for short-term operation.
3. Please replace lubricant once per year or per 2400 hours for long-term operation.

螺旋傘齒輪轉向器系列

BEVEL GEAR REDUCER SERIES

MODEL : TH-15AW

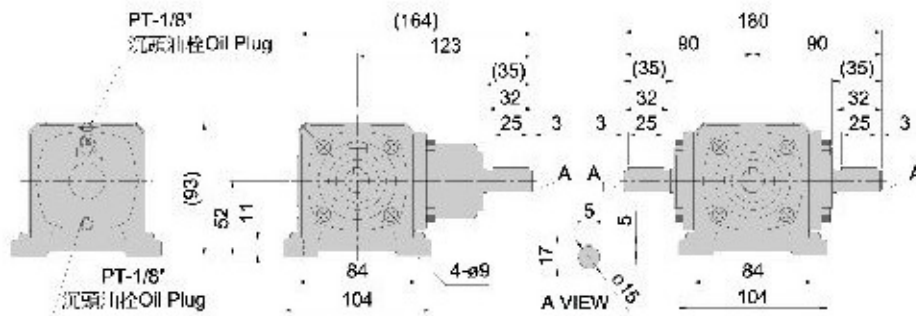

MODEL : TH-15BW

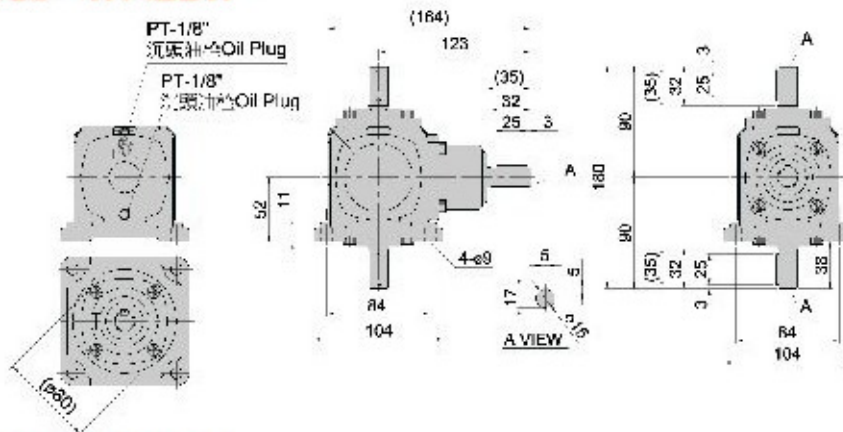

MODEL : TH-15CW

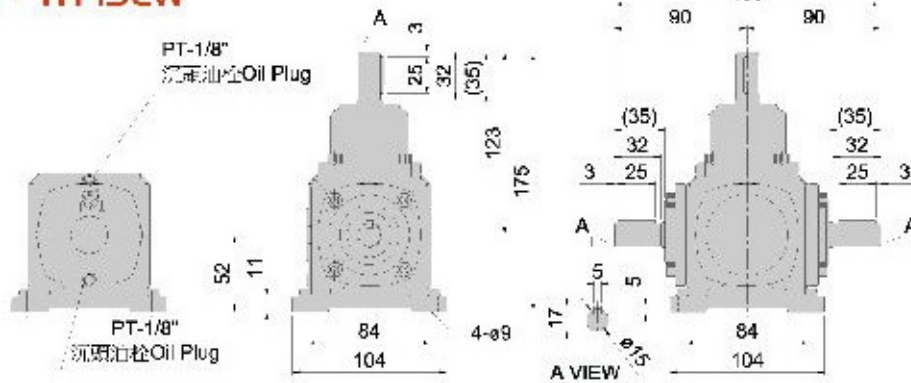

MODEL : TH-15DW

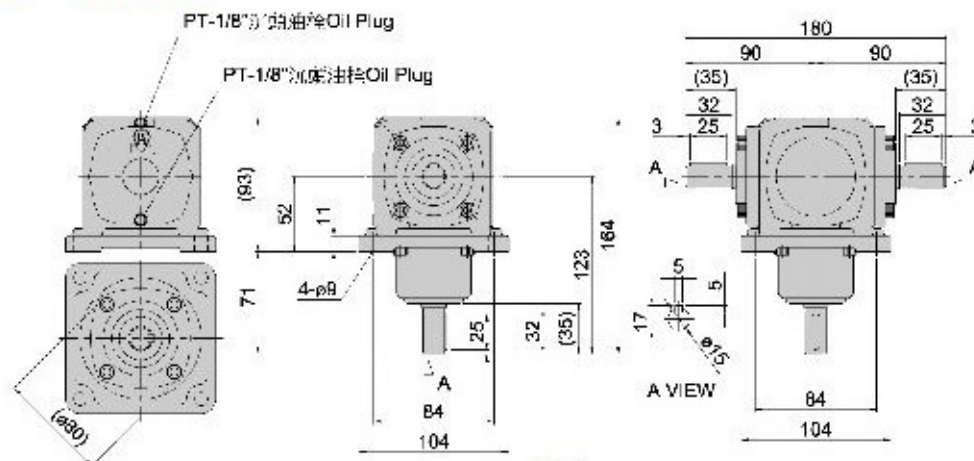



螺旋傘齒輪轉向器系列 BEVEL GEAR REDUCER SERIES

MODEL : TH-25AW

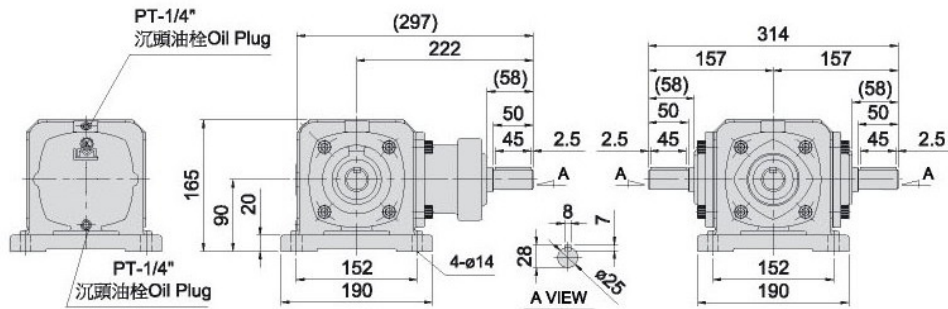

MODEL : TH-25BW

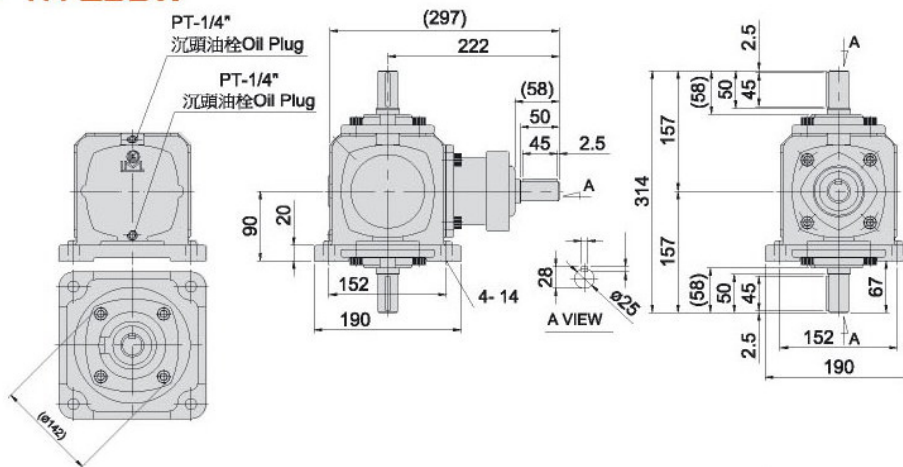

MODEL : TH-25CW

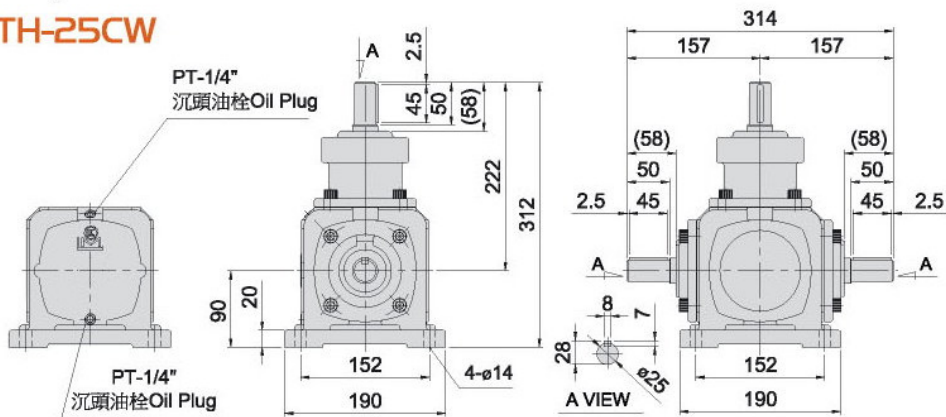

MODEL : TH-25DW

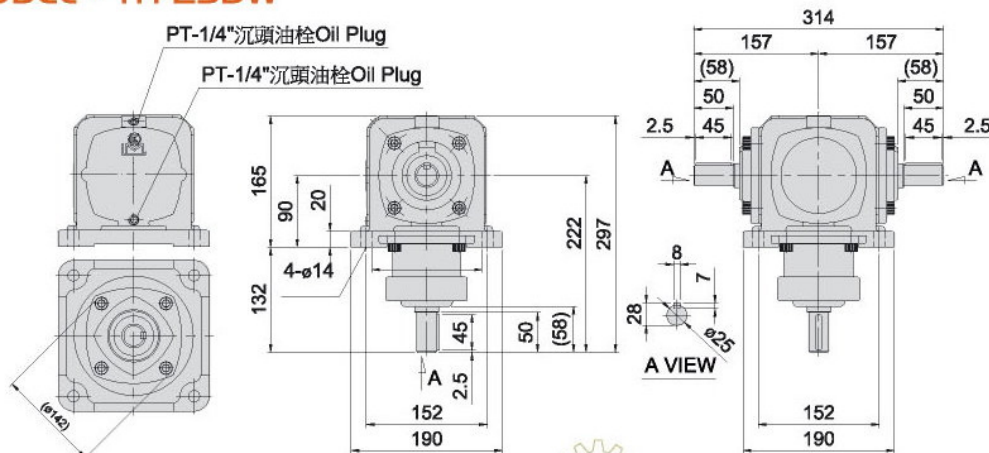

■ MODEL : TH-40AW

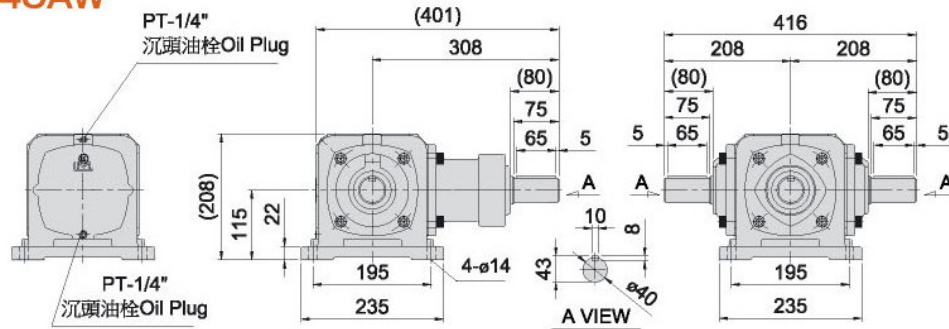

■ MODEL : TH-40BW

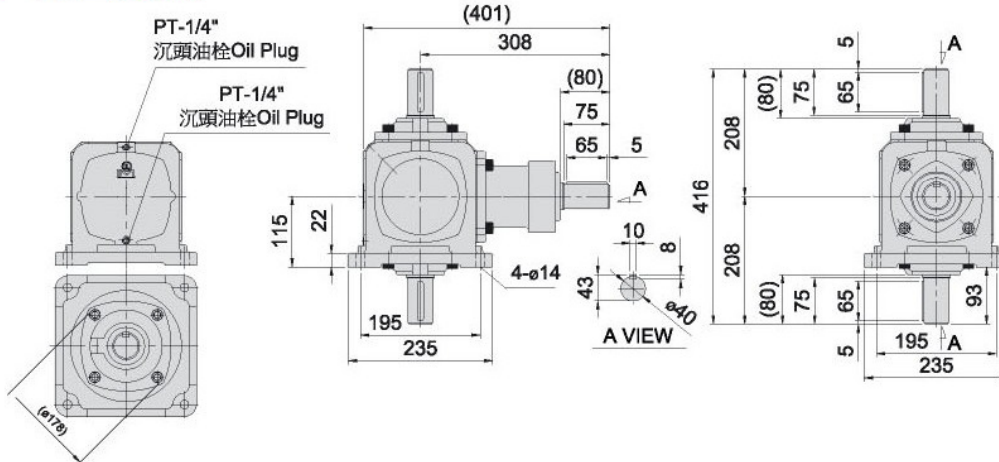

■ MODEL : TH-40CW

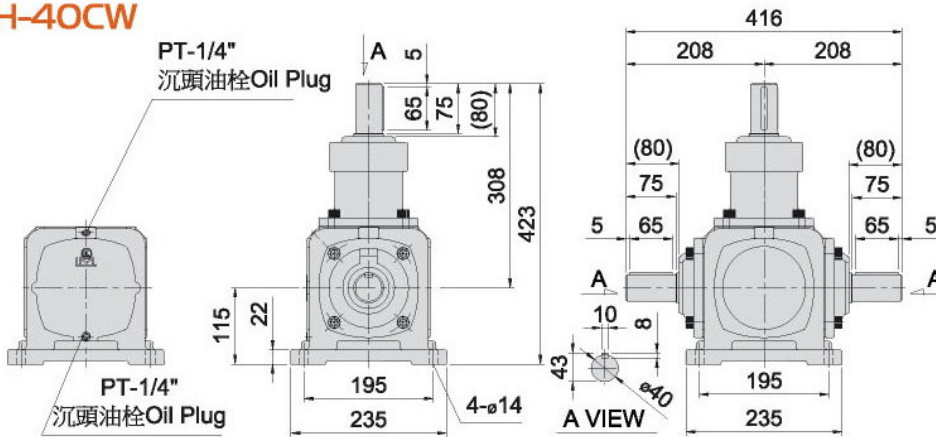

■ MODEL : TH-40DW

